

Installation, Operation and Maintenance Manual for
Pressure/Vacuum Relief Valves (Spring Loaded)

**Models 1201B, 1202B 1203A, 1221B, 1222B, 1223A, 1261A,
1301A, 1361A, 2301A**

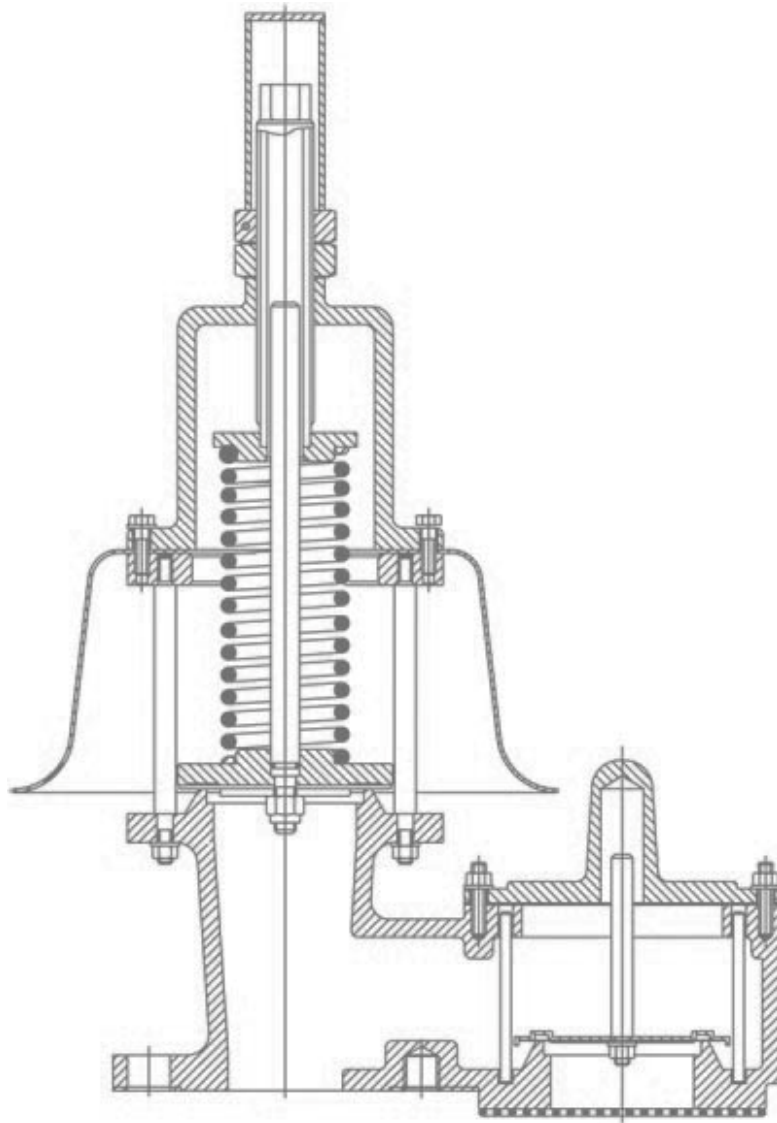

TABLE OF CONTENTS:

INTRODUCTION:	3
DESIGN, FUNCTION & OPERATION	4
GENERAL SAFETY INSTRUCTIONS	5
SAFETY WARNINGS	5
INSPECTION AND INSTALLATION	6
TABLE 1: STUD SELECTION	6
TABLE 2: BOLT TORQUE CHART	6
PREVENTIVE MAINTENANCE	7
RECOMMENDED SPARE PARTS	7
TABLE 3: PART NUMBER FOR RECOMMENDED SOFT GOOD SPARE PARTS	7
TABLE 4: VALVE DIAPHRAGM USAGE, BASED ON SETTING	7
TABLE 5: REPLACEMENT CARBON STEEL SPRING PART NUMBERS	8
TABLE 6: REPLACEMENT STAINLESS STEEL PART NUMBERS	8
DISASSEMBLY	9
TABLE 7: STEM LENGTH	9
TABLE 8: RECOMMENDED PALLET ASSEMBLY TORQUE	9
TESTING AND SETTING PROCEDURE	13
TABLE 9 - NOMINAL PALLET ASSEMBLY WEIGHT PER UNIT OF PRESSURE	13
MODEL INFORMATION	19
PRODUCT LIMITED WARRANTY	19

INTRODUCTION:

The Groth Spring-Loaded Pressure / Vacuum Relief Valves (PV) are designed to protect tanks from damage caused by overpressure or over vacuum conditions. By containing product vapors PV valves reduce costly product evaporation losses due to normal tank breathing. In addition, atmospheric contamination is reduced by containing product vapors until tank pressure reaches the set pressure of the PV valve.

All pallets include Groth's special "cushioned air" seating. Teflon® seating diaphragms are standard; they minimize sticking caused by resinous vapors and atmospheric moisture. The valve has a self draining housing body and drip rings to protect seating surfaces from condensate and freezing. This design also avoids dangerous pressure or vacuum buildup due to binding or clogging of the vent. Diaphragms are available in Buna-N, Viton and other elastomers; metal-to-metal seat can be provided when required.

To insure the proper alignment of seating surfaces, there is both peripheral and stem pallet guidance. As with all Groth products, every spring loaded valve is factory inspected and tested.

Pressure and Vacuum Relief Valves are preset at the factory in accordance with the purchase order. These settings are printed on the stainless steel name tag.

All PV valves require regular inspection and maintenance, the frequency depending upon actual conditions. The gasket between the vent and the nozzle flange should also be regularly inspected.

The valve must be maintained by a knowledgeable valve technician. It should only be assembled under clean conditions - preferably in a shop environment. Carefully read and understand this Manual before installing or repairing this valve.

For information not contained in this manual, please contact:

Groth Corporation
13650 N. Promenade Blvd
Stafford, TX 77477
281-295-6800 (Phone)
281-295-6995 (Fax)

DESIGN, FUNCTION & OPERATION

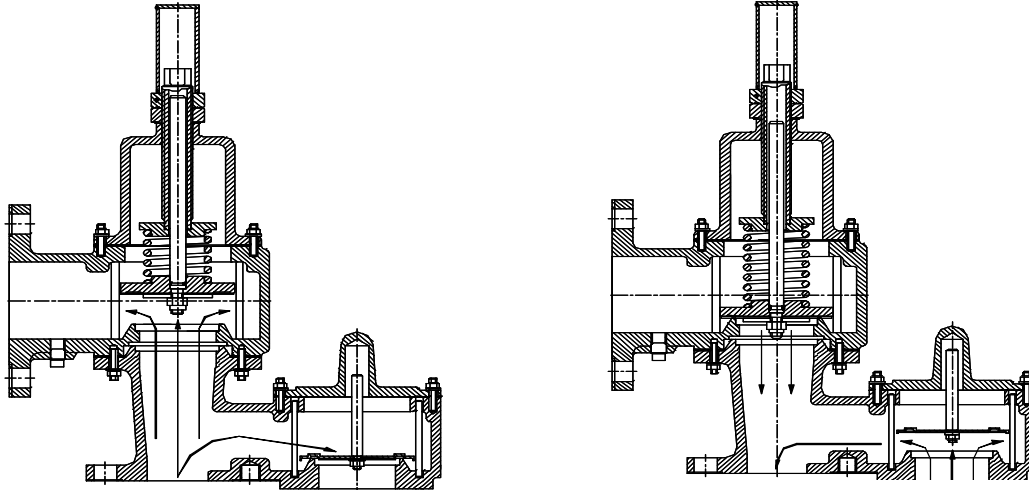

Pressure Relief : As the pressure in the storage tank increases the vacuum pallet is held shut. When the set pressure is reached the pressure pallet lifts and relieves to a header (or to atmosphere if it is not a pipe away valve).

Vacuum Relief : As a vacuum is drawn on the storage tank (for example, when fluid is being pumped out), the pressure pallet is held shut by tank vacuum. When the vacuum setting is reached, the pallet lifts and air is drawn in from the atmosphere and flows into the tank.

NOTE 1: Minimum recommended clearance between vacuum inlet port and tank roof is nominal flange bore of valve.

Typical valve installation on a tank or vessel is illustrated in Fig.1 on the next page using a Model 1221A Pressure/Vacuum Relief Valve. Most tanks will have provision for an operating relief valve, an emergency relief valve, and a blanketing regulator that maintains a positive gas pressure in the tank.

The combination of these valves and regulator are designed to ensure that the tank is protected from both excess vacuum and pressure conditions.

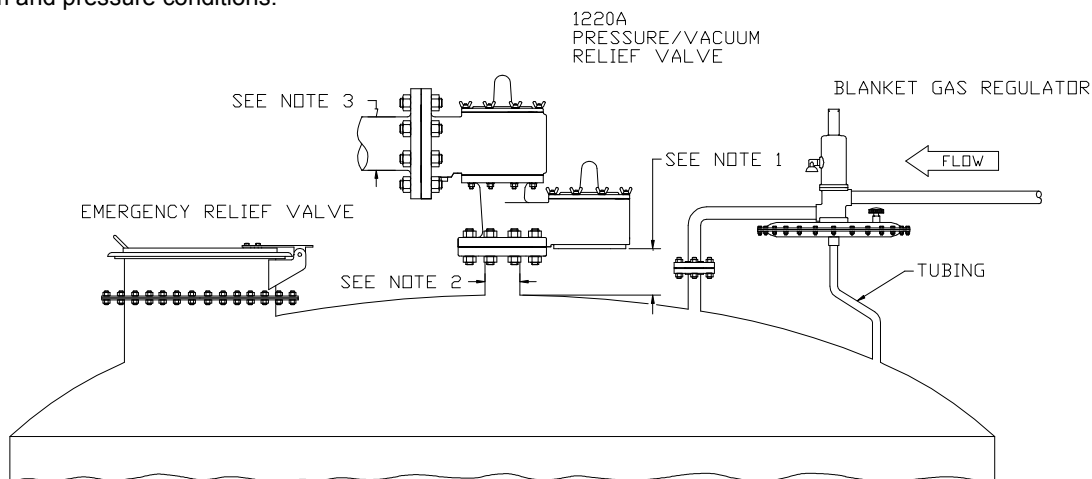

Figure 1 - Typical Tank Installation

Tank protection equipment typically includes an operating valve which is designed to provide pressure/vacuum relief under normal pump in/out and thermal breathing conditions. An emergency relief valve can also provide both pressure and vacuum relief, normally sized to provide pressure relief if there is a fire in the immediate vicinity of the tank. It may also be sized by the tank designer to provide protection in the event of equipment failure (such as the rupture of a process steam line or an inert gas blanketing system failing "wide open") or operator error.

A typical tank installation is shown in Fig. 1 which includes the following Groth products:

- Model 1221B PV' Valve
- Model 3011 Blanket Gas Regulator
- Model 2400 Emergency Relief Valve

GENERAL SAFETY INSTRUCTIONS

This section is an overview of safety guidelines that should be followed during the installation, operation and maintenance of Groth Pressure / Vacuum Relief Valves. To understand the context of these instructions and warnings, it is necessary to completely read and understand the contents of this manual.

The purpose of a pressure/vacuum relief valve is to prevent excessive pressure or vacuum in a tank or process system. The valve must be designed for the proper MAWP and flow requirements of the system. Consult API Standard 2000 for tank protection sizing procedures. An improperly specified or functioning relief valve may result in structural damage to the tank or system, and can cause severe personal injury or death.

SAFETY WARNINGS

PRESSURE/VACUUM CONSERVATION VALVES ARE DESIGNED TO PROVIDE FULL RATED CAPACITY AT 100% OVER-PRESSURE. IF THE VALVE IS TO BE OPERATED AT A REDUCED OVER-PRESSURE, CONSULT FACTORY FOR ACTUAL FLOW CAPACITY UNDER SPECIFIED CONDITIONS.

THE TANK PRESSURE REQUIRED TO DISCHARGE THE NORMAL OR EMERGENCY VENTING REQUIREMENTS OF THE TANK WILL BE INCREASED BY THE AMOUNT OF BACK PRESSURE IN THE DISCHARGE HEADER, ON A PIPE AWAY VALVE CONFIGURATION. MAXIMUM POSSIBLE DISCHARGE HEADER PRESSURE MUST BE CONSIDERED WHEN SIZING THE PRESSURE RELIEF VALVE.

DO NOT CHANGE PRESSURE RATING BY ADDING ADDITIONAL WEIGHTS TO PALLET ASSEMBLY OR ADJUSTING SPRING COMPRESSION WITHOUT CONSULTING FACTORY. ADDING WEIGHTS OR ADJUSTING SPRING COMPRESSION TO A VALVE MAY RESTRICT PALLET LIFT AND REDUCE FLOW CAPACITY. DO NOT CHANGE PRESSURE RATINGS BY ADDING ADDITIONAL WEIGHTS TO THE PALLET ASSEMBLY WITHOUT CONSULTING THE FACTORY OR YOUR LOCAL GROTH REPRESENTATIVE. ADDING WEIGHTS TO A VALVE MAY RESTRICT PALLET LIFT AND REDUCE THE VALVES' RATED FLOW CAPACITY.

WHEN INSTALLING THE WEIGHT LOADED PALLET ASSEMBLY IN THE VALVE, MAKE SURE THAT THE STEM IS STRAIGHT AND FITS INTO THE GUIDE IN THE COVER. IF THE STEM IS COCKED, THE PALLET ASSEMBLY MAY NOT OPEN FULLY AND THE TANK CAN BE OVER-PRESSURED. UNDER THESE CONDITIONS, THE VALVE WILL NOT PROTECT THE TANK FROM RUPTURING DUE TO CHANGES IN INTERNAL PRESSURE. TANK FAILURE CAN CAUSE MATERIAL DAMAGE AND LOSS AND RESULT IN SEVERE PERSONAL INJURY OR DEATH.

DO NOT MIX WEIGHT LOADED PALLET ASSEMBLIES FROM DIFFERENT VALVES. FAILURES TO ENSURE THAT THE WEIGHT LOADED PALLET ASSEMBLIES ARE INSTALLED IN THE ORIGINAL AND CORRECT LOCATION CAN CHANGE THE PRESSURE OR VACUUM RELIEF SETTINGS. THIS CAN CAUSE A TANK FAILURE.

DO NOT LOOSEN HEX NUTS UNTIL ALL SPRING COMPRESSION HAS BEEN RELEASED. SPRING PRE-LOAD IS SUBSTANTIAL AND COULD CAUSE SEVERE PERSONAL INJURY IF FASTENERS WERE REMOVED WITH THE SPRING COMPRESSED.

DO NOT ATTEMPT TO REMOVE THE VALVE FROM THE TANK OR PROCESS VESSEL WITHOUT FIRST BLEEDING ALL PRESSURE FROM THE SYSTEM. ALTERNATIVE MEANS OF PRESSURE RELIEF MUST BE PROVIDED WHEN THE VALVE IS OUT OF SERVICE.

THE VALVE HAS BEEN EXPOSED TO PROCESS VAPORS WHILE IN SERVICE. OBSERVE ALL PLANT PROCEDURES AND MATERIAL SAFETY DATA SHEETS (MSDS) FOR THE PRODUCTS IN THE SYSTEM WHEN INSPECTING, ADJUSTING OR SERVICING THE VALVE. TAKE APPROPRIATE SAFETY PRECAUTIONS REGARDING EYE PROTECTION, RESPIRATION AND SKIN CONTACT.

DO NOT ADD ANY WEIGHT TO THE PALLET ASSEMBLY, CHANGE THE ADJUSTMENT SCREW (CHANGING SET PRESSURE OR VACUUM), OR CHANGE PALLET STEM WITHOUT FIRST CONSIDERING THE ALLOWABLE TANK PRESSURE OR WITHOUT MEASURING DESIGN LIFT TO ENSURE THE LIFT IS NOT RESTRICTED. RESTRICTING VALVE LIFT COULD "CHOKE" THE VALVE AND NOT ALLOW FOR FULL RATED CAPACITY. CHANGING THE WEIGHT OR ADJUSTMENT OF A SPRING COULD ALSO RESTRICT THE LIFT OF A VALVE AT A SPECIFIED OVERPRESSURE, REDUCING THE RATED CAPACITY OF THE VALVE. UNDER THESE CONDITIONS, THE VALVE WILL NOT PROTECT THE TANK FROM RUPTURING DUE TO CHANGES IN INTERNAL PRESSURE. TANK FAILURE CAN CAUSE MATERIAL DAMAGE AND LOSS AND RESULT IN SEVERE PERSONAL INJURY OR DEATH.

INSPECTION AND INSTALLATION

The pressure/vacuum relief valve is carefully packaged to prevent damage or contamination during shipping. Inspect all equipment when it is received; report any damage to the carrier immediately. The valve should be protected during handling and storage. Keep all the ports plugged to prevent intrusion of foreign materials. Before installation, inspect the unit for indications of physical damage or internal contamination. If these are observed, the valve must be disassembled, cleaned and repaired before installation.

Groth's spring loaded PV Valves are designed to provide tank protection for set-pressures to 15 PSIG and vacuum to 12 PSIG. The valves provide full rated flow capacity at 100% over-pressure. Consult factory for performance under other conditions.

The valve should be installed in a vertical position as shown in Figure 1.

Follow the torque guidelines listed in Table 2 to avoid produce damage due to excessive fastener tightening. The valves are NOT rated for full flange pressure and do not require high bolting torque. Consult factory for special applications; torque values assume a maximum MAWP of 30 PSIG.

The following guidelines should be observed at installation:

1. Remove any flange protectors and discard all packing material.
2. Inspect the gasket seating surface of the tank nozzle flange. It must be clean, free of scratches, corrosion, tool marks, and flat.
3. Aluminum valves are furnished with flat face flanges; they should only be installed on a mating flat faced flange with a full faced gasket.
4. Inspect the gasket; make sure that the material is suitable for the application.
5. Lubricate all studs and nuts with an appropriate thread lubricant. If the valve will see high temperature service or stainless steel fasteners are used, select an anti-seize compound such as moly-disulfide.
6. Center the gasket within the bolt circle.
7. Set the valve carefully on the nozzle. Install the studs and tighten nuts hand tight. For stud selection for blind tapped holes see Table 1 below :

Inlet Flange	Thread Size	Recommended Stud Length
2"	5/8" - 11	2.25"
3"	5/8" - 11	2.50"
4"	5/8" - 11	2.50"
6"	3/4" - 10	3.00"
8"	3/4" - 10	3.00"
10"	7/8" - 9	3.50"
12"	7/8" - 9	3.50"

Inlet Flange	Raised Face	Flat Face	Number Bolts
2"	30 [3.4]	60 [6.8]	4
3"	54 [6.1]	108 [12.2]	4
4"	42 [4.7]	78 [8.8]	8
6"	90 [10.2]	150 [16.9]	8
8"	126 [14.2]	228 [25.8]	8
10"	138 [15.6]	246 [27.8]	12
12"	186 [21.0]	348 [39.3]	12

*Average values based on a nitrile binder synthetic gasket, 1/32" thick and lubricated threads.

8. Torque all fasteners to half the value listed in the table below in a staggered, alternating pattern.
9. Make sure that the flanges are not distorted and that the gasket is evenly compressed.
10. Make up the final torque and check that no further nut rotation occurs at the specified torque value, as specified in Table 2.

PREVENTIVE MAINTENANCE

Groth Corporation recommends that all service performed on a pressure/vacuum relief valve be done at the factory or a factory authorized repair center. Trained mechanics with specialized test equipment will ensure that the valve is properly maintained and accurately set.

It is important to regularly inspect and clean the diaphragm, guides and seating surfaces for the most effective valve performance. Frequency of valve inspection and maintenance should be based on the experience gained in each application. It is recommended that the valve be removed for inspection of wetted components at least once per year. Refer to Fig. 5 which illustrates a typical Pressure/Vacuum relief valve to disassemble the unit.

RECOMMENDED SPARE PARTS

The following spare parts should be stocked for maintenance purposes:

TABLE 3: PART NUMBER FOR RECOMMENDED SOFT GOOD SPARE PARTS

VALVE SIZE	FEP Diaphragm 20 mil (Spring Loaded)	FEP Diaphragm 10 mil (Weight Loaded)	FEP Diaphragm 20 mil (Weight Loaded)	Gasket, Outlet Teflon (bottom)	Gasket, Cover Teflon (top)	O-Ring (machined pallet) Viton®
2"	DPH1201027320	DPH1200027310	DPH1200027320	GKT1220027102	GKT1200027101	0267010U2
3"	DPH1201037320	DPH1200037310	DPH1200037320	GKT1220037102	GKT1200037101	
4"	DPH1201047320	DPH1200047310	DPH1200047320	GKT1220047102	GKT1200047101	
6"	DPH1201067320	DPH1200067310	DPH1200067320	GKT1220067102	GKT1200067101	0267012U2
8"	DPH1201087320	DPH1200087310	DPH1200087320	GKT1220087102	GKT1200087101	
10"	DPH1201107320	DPH1200107310	DPH1200107320	GKT1220107102	GKT1200107101	
12"	DPH1201127320	DPH1200127310	DPH1200127320	GKT1220127102	GKT1200127101	

TABLE 4: VALVE DIAPHRAGM USAGE, BASED ON SETTING

Setting	< 4 OSI		4 - 8 OSI		> 8 OSI	
Diaphragm	10 mil	20 mil	10 mil	20 mil	10 mil	20 mil
Quantity	1	---	---	1	1	1

* Please provide the valve serial number and pressure/vacuum settings when ordering replacement parts.

Replacement Springs

To order original Groth replacement springs, find the desired pressure range from the tables below and select the corresponding part number for the valve size:

TABLE 5: REPLACEMENT CARBON STEEL SPRING PART NUMBERS

Set Range PSIG	Carbon Steel Spring Part Numbers (*)						
	2"	3"	4"	6"	8"	10"	12"
1.0 to 1.3	SPR1201020120	SPR1201030120	SPR1201040120	SPR1201060120	SPR1201080120	SPR1201100120	SPR1201120120
1.4 to 1.8	SPR1201020220	SPR1201030220	SPR1201040220	SPR1201060220	SPR1201080220	SPR1201100220	SPR1201120220
1.9 to 2.4	SPR1201020320	SPR1201030320	SPR1201040320	SPR1201060320	SPR1201080320	SPR1201100320	SPR1201120320
2.5 to 3.2	SPR1201020420	SPR1201030420	SPR1201040420	SPR1201060420	SPR1201080420	SPR1201100420	SPR1201120420
3.3 to 4.2	SPR1201020520	SPR1201030520	SPR1201040520	SPR1201060520	SPR1201080520	SPR1201100520	SPR1201120520
4.3 to 5.5	SPR1201020620	SPR1201030620	SPR1201040620	SPR1201060620	SPR1201080620	SPR1201100620	SPR1201120620
5.6 to 7.2	SPR1201020720	SPR1201030720	SPR1201040720	SPR1201060720	SPR1201080720	SPR1201100720	SPR1201120720
7.3 to 9.4	SPR1201020820	SPR1201030820	SPR1201040820	SPR1201060820	SPR1201080820	SPR1201100820	SPR1201120820
9.5 to 12.2	SPR1201020920	SPR1201030920	SPR1201040920	SPR1201060920	SPR1201080920	SPR1201100920	SPR1201120920
12.3 to 15.0	SPR1201021020	SPR1201031020	SPR1201041020	SPR1201061020	SPR1201081020	SPR1201101020	SPR1201121020

TABLE 6: REPLACEMENT STAINLESS STEEL PART NUMBERS

Set Range PSIG	17-7 PH Stainless Steel Spring Part Numbers (*)						
	2"	3"	4"	6"	8"	10"	12"
1.0 to 1.3	SPR1201020105	SPR1201030105	SPR1201040105	SPR1201060105	SPR1201080105	SPR1201100105	SPR1201120105
1.4 to 1.8	SPR1201020205	SPR1201030205	SPR1201040205	SPR1201060205	SPR1201080205	SPR1201100205	SPR1201120205
1.9 to 2.4	SPR1201020305	SPR1201030305	SPR1201040305	SPR1201060305	SPR1201080305	SPR1201100305	SPR1201120305
2.5 to 3.2	SPR1201020405	SPR1201030405	SPR1201040405	SPR1201060405	SPR1201080405	SPR1201100405	SPR1201120405
3.3 to 4.2	SPR1201020505	SPR1201030505	SPR1201040505	SPR1201060505	SPR1201080505	SPR1201100505	SPR1201120505
4.3 to 5.5	SPR1201020605	SPR1201030605	SPR1201040605	SPR1201060605	SPR1201080605	SPR1201100605	SPR1201120605
5.6 to 7.2	SPR1201020705	SPR1201030705	SPR1201040705	SPR1201060705	SPR1201080705	SPR1201100705	SPR1201120705
7.3 to 9.4	SPR1201020805	SPR1201030805	SPR1201040805	SPR1201060805	SPR1201080805	SPR1201100805	SPR1201120805
9.5 to 12.2	SPR1201020905	SPR1201030905	SPR1201040905	SPR1201060905	SPR1201080905	SPR1201100905	SPR1201120905
12.3 to 15.0	SPR1201021005	SPR1201031005	SPR1201041005	SPR1201061005	SPR1201081005	SPR1201101005	SPR1201121005

DISASSEMBLY

WEIGHT LOADED PALLET ASSEMBLY

1. Loosen and remove all hex nuts and washers.
2. Remove the vent cover or weatherhood from the valve body.
3. Remove the pallet assembly by firmly grasping the stem and lifting up. Depending on the pressure/vacuum settings of the particular valve, weight plates may have been added to the pallet assembly. The weights and pallets must be reinstalled in their original locations. Make sure that all weight plates stay with the appropriate pallet assembly. If working with more than one valve tag the assemblies as they are removed from the valves.
4. Carefully inspect all guides for corrosion, damage or product build up. Also inspect the guide hole in the vacuum cover. Check the metal seating surfaces for pitting or build up. It is recommended to replace all soft goods including diaphragm, O-Ring (for machined pallets, Figure 2) and cover gasket.

TABLE 7: STEM LENGTH - IN. [CM]

Valve Size In [mm]	Valve Model			
	2300A	1200A	1220A / 1260A	1300A / 1360A
	Pressure Port		Vacuum Port	
2 [50]	5.50 [14.0]		4.63 [11.8]	4.63 [11.8]
3 [80]	5.50 [14.0]		5.50 [14.0]	5.50 [14.0]
4 [100]	7.81 [19.8]		7.81 [19.8]	5.50 [14.0]
6 [150]	10.75 [27.3]		10.75 [27.3]	7.19 [18.3]
8 [200]	10.75 [27.3]		12.13 [30.8]	10.75 [27.3]
10 [250]	10.75 [27.3]		13.50 [34.3]	10.75 [27.3]
12 [300]	12.13 [30.8]		15.00 [38.1]	12.13 [30.8]

TABLE 8: RECOMMENDED PALLET ASSEMBLY TORQUE

STEM THREAD SIZE	PALLET ASSEMBLY TORQUE REQUIREMENT FT-LBS [N-m]	
	KYNAR STEM	METALLIC STEM (ALUMINUM / STAINLESS STEEL)
1/4"	HAND TIGHT	4 [5.4]
3/8"	HAND TIGHT	16 [21.7]
1/2"	HAND TIGHT	N / A

NOTE: If the seat is damaged it must be lapped using a ground flat metal disc and a fine grit emery cloth attached to the disc. Wipe seating surface clean before proceeding.

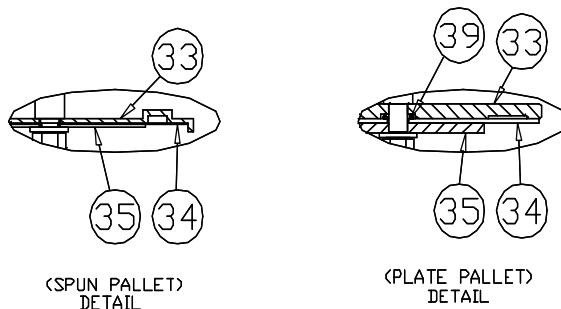

Figure 2 - Pallet Assembly Detail

5. Prior to final assembly, verify that the pallet and weights are back in their proper location. Assemble in reverse order. Make sure that pallet assembly is flat on the seat and that the stem is not cocked when the cover is installed. Oil, grease or other lubricant are not required on guides or other metal surfaces of valves, and can hinder free movement. If the valve is in high temperature service or stainless steel external fasteners are used, apply an anti-seize compound such as moly-disulfide to all threaded components. Tighten all hex nuts firmly.

SPRING LOADED PALLET ASSEMBLY

1. Remove cap and hex jam nut.
2. Carefully measure and record the distance from the top of the adjustment screw to the top of the spring chamber. (Dimension "D" - See Figure 3).
3. Relieve all spring compression by turning the adjustment screw counterclockwise.
4. Loosen and remove all hex nuts and washers.
5. Lift the spring chamber from the body.
6. Remove the upper spring button and spring. Remove the pallet assembly by firmly grasping the stem and lifting up. If more than one valve is being disassembled, tag the assemblies as they are removed from the valves.
7. Carefully inspect all guides for corrosion, damage or product build up. Also inspect the adjustment screw and spring chamber (#2) for thread damage or galling. Check the metal seating surfaces for pitting or build up. It is recommended that all soft goods including diaphragms, O-Ring and spring chamber gasket be replaced.

NOTE: If the seat is damaged it must be lapped using a ground flat metal disc and a fine grit emery cloth attached to the disc. Wipe seating surface clean before proceeding.

8. Prior to final assembly, verify that the pallet and spring are back in their proper location. Assemble in reverse order. Make sure that pallet assembly is flat on the seat and that the stem is not cocked when the spring chamber is installed. Oil, grease or other lubricant are not required on guides or other metal surfaces of valves, and can hinder free movement. Lubricate the adjustment screw threads with an appropriate thread lubricant. If the valve is in high temperature service or stainless steel external fasteners are used, apply an anti-seize compound such as moly-disulfide to all threaded components. Tighten all hex nuts firmly.
9. If the spring is being re-used, compress it by turning the adjustment screw clockwise until the distance from the top of the adjustment screw to the top of spring chamber matches the distance "D" measured in Step 2; proceed to Step 11.
10. If the spring is replaced, use only original springs supplied by Groth Corporation and follow the Procedure illustrated below:
11. Replace and tighten hex jam nut firmly. Replace cap.

Figure 3: Spring Setting Procedure

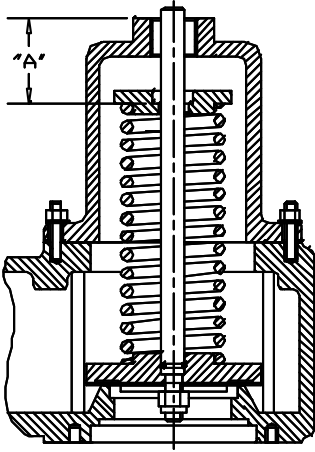
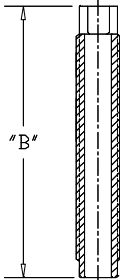
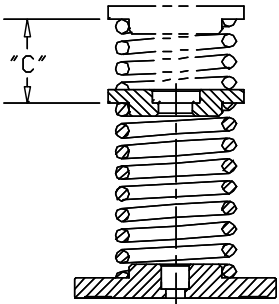
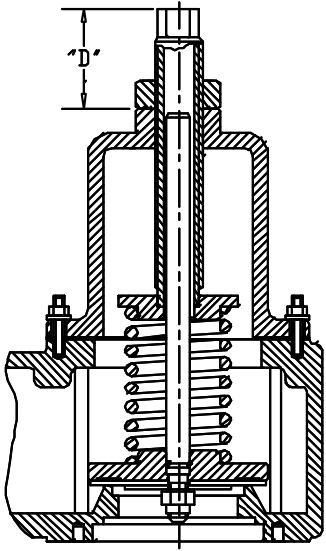
STEP 1	STEP 2	STEP 3	STEP 4
 <p>After removing the adjustment screw (#4) measure the distance from top of spring chamber to counter bore on spring button for the dimension "A".</p>	 <p>Measure overall length of adjustment screw for dimension "B".</p>	 <p>This is the required compression to achieve the design set pressure. Consult factory for determination of "C" dimension.</p>	 <p>Use the following calculation to obtain the "D" dimension. Compress the spring by turning the adjustment screw clockwise accordingly.</p> <p style="text-align: center;">D = B-A-C</p>

TESTING AND SETTING PROCEDURE

- Before starting to reassemble a valve, calculate the nominal pressure and vacuum pallet assembly weights, as shown in Example 1. Weigh all pallet assemblies to ensure the correct settings. Record pallet assembly weight(s) on factory test report.

Example: Pallet Assembly Weight Calculation (PAW)

6" Valve set at 7.5 OSI Read weight at 1.0 OSI from table 10 Weight = 3.04 Lb.
 Multiple weight by set pressure PAW (*) = 3.04 x 7.5 = 22.8 Lb.

(*) = Includes pallet, retainer plate, stem, diaphragm, weight plates and fasteners.

TABLE 9 - NOMINAL PALLET ASSEMBLY WEIGHT PER UNIT OF PRESSURE (*)

SET	Valve Size													
	2"		3"		4"		6"		8"		10"		12"	
	[Lb.]	[kg]	[Lb.]	[kg]	[Lb.]	[kg]	[Lb.]	[kg]	[Lb.]	[kg]	[Lb.]	[kg]	[Lb.]	[kg]
1.0 OSI	0.41	0.18	0.84	0.38	1.42	0.64	3.04	1.38	5.28	2.40	7.52	3.42	10.1	4.61
1.0 IN WC	0.24	0.11	0.48	0.22	0.82	0.37	1.76	0.80	3.05	1.39	4.35	1.98	5.86	2.67
1.0 mbar	0.09	0.04	0.19	0.09	0.33	0.15	0.71	0.32	1.23	0.56	1.74	0.79	2.35	1.07

- After final assembling, mount the valve on a Tank Vent Test Stand (TVTS) and slowly raise the pressure at the flow rate specified below:

Valve Size	Test Flow Rate
2" - 6"	0.5 SCFH
8"- 12"	5.0 SCFH

ACCEPTANCE CRITERIA: The pressure gauge shall maintain a pressure equal to or greater than 75% of set pressure for a one minute period while the specified flow rate is maintained. This test shall be successfully performed three consecutive times.

- If the valve fails to meet the 75% criteria, it must be disassembled and the seat, pallet, and or diaphragms repaired or replaced.
- Set pressure and / or vacuum must also be tested. To test for set pressure / vacuum, slowly increase the pressure / vacuum to the valve being tested. Increase until there is audible leakage from the valve seat. Closely monitor the pressure / vacuum at the gauge, when an increase in flow to the valve no longer raises the pressure at the gauge the set pressure / vacuum is reached.
- Repeat Step 4 three consecutive times. Record all three tests on the factory test report.
- A copy of the Test Report shall be maintained with the Valve Maintenance Records.

Groth Model 1201B Pressure/Vacuum Relief Valve

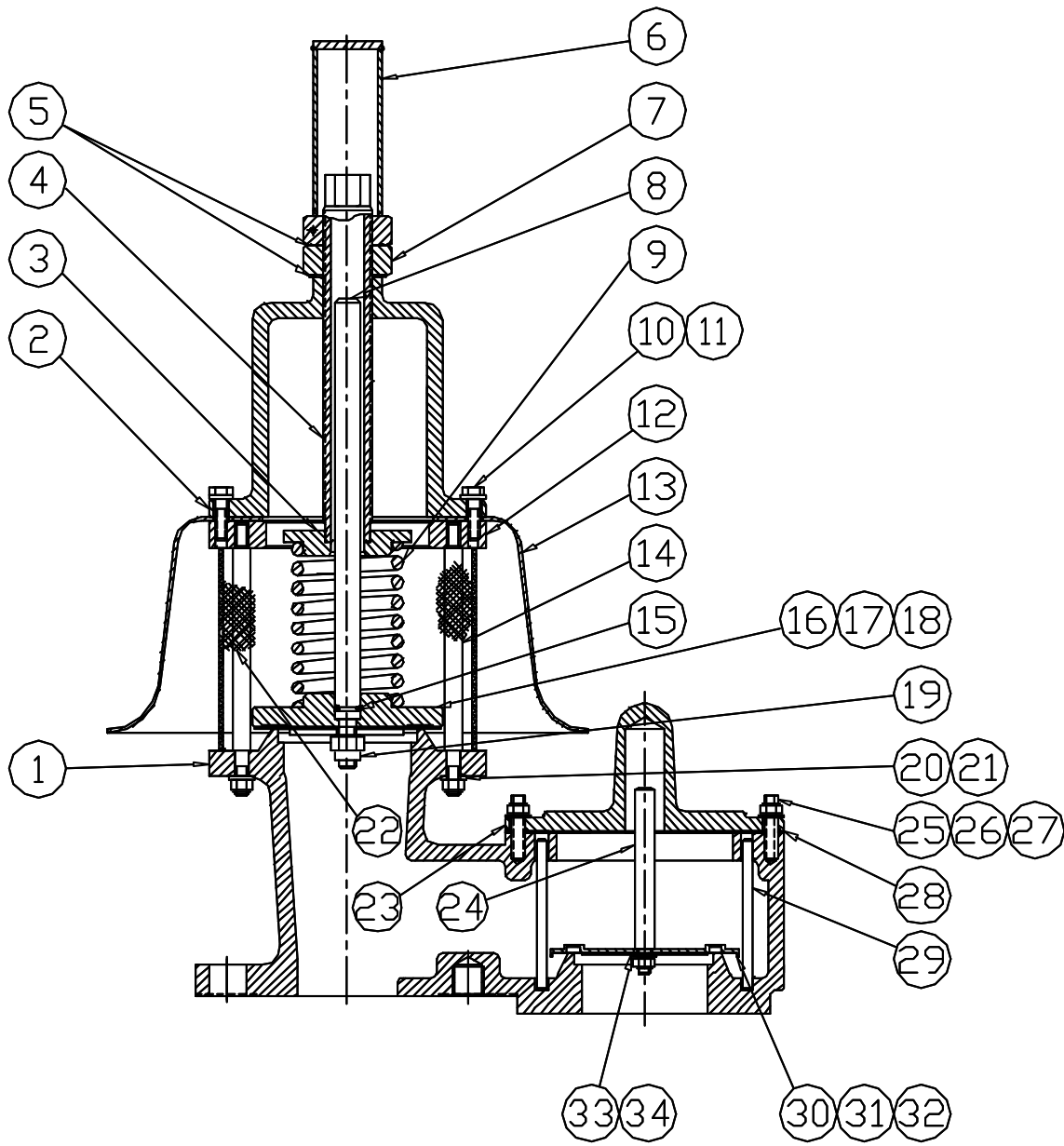

ITEM	DESCRIPTION	CARBON	ALUMINUM	STAINLESS
1	Body	CS	Aluminum	316 SS
2	Spring Chamber	CS	Aluminum	316 SS
3	Spring Button	CS	CS	316 SS
4	Adjustment Screw	SS	SS	SS
5	Gasket, Cap *	SS	SS	SS
6	Cap	CS	CS	316 SS
7	Hex Jam Nut	CS	CS	SS
8	Stem	316 SS	316 SS	316 SS
9	Spring	CS	CS	SS
10	Hex Bolt	CS	CS	316 SS
11	Lock Washer	CS	CS	316SS
12	Support Ring	CS	CS	316 SS
13	Weatherhood	CS	Aluminum	316 SS
14	Weatherhood Post	316 SS	316 SS	316 SS
15	O-Ring *	Viton	Viton	Viton
16	Pallet	316 SS	316 SS	316 SS
17	Diaphragm *	Teflon®	Teflon®	Teflon®
18	Retainer Plate	316 SS	316 SS	316 SS
19	Hex Lock Nut	316 SS	316 SS	316 SS
20	Lock Washer	CS	CS	316SS
21	Hex Nut	CS	CS	316SS
22	Screen	SS	SS	316 SS
23	Vent Cover - Vac	CS	Aluminum	316 SS
24	Stem - Vac	316 SS	316 SS	316 SS
25	Stud	CS	CS	316SS
26	Lock Washer	CS	CS	316SS
27	Hex Nut	CS	CS	316 SS
28	Gasket-Cover, Vac *	Non-Asb	Non-Asb	Non-Asb
29	Guide Post - Vac	316 SS	316 SS	316 SS
30	Pallet - Vac	316 SS	316 SS	316 SS
31	Diaphragm - Vac *	Teflon®	Teflon®	Teflon®
32	Retainer Plate - Vac	316 SS	316 SS	316 SS
33	Lock Washer	316 SS	316 SS	316 SS
34	Hex Nut	316 SS	316 SS	316 SS
35	O-Ring (Machined Pallet) * #	Viton	Viton	Viton

* = Recommended Spare Parts

= See Figure 2 Item 39

Groth Model 1221B Pressure/Vacuum Relief Valve

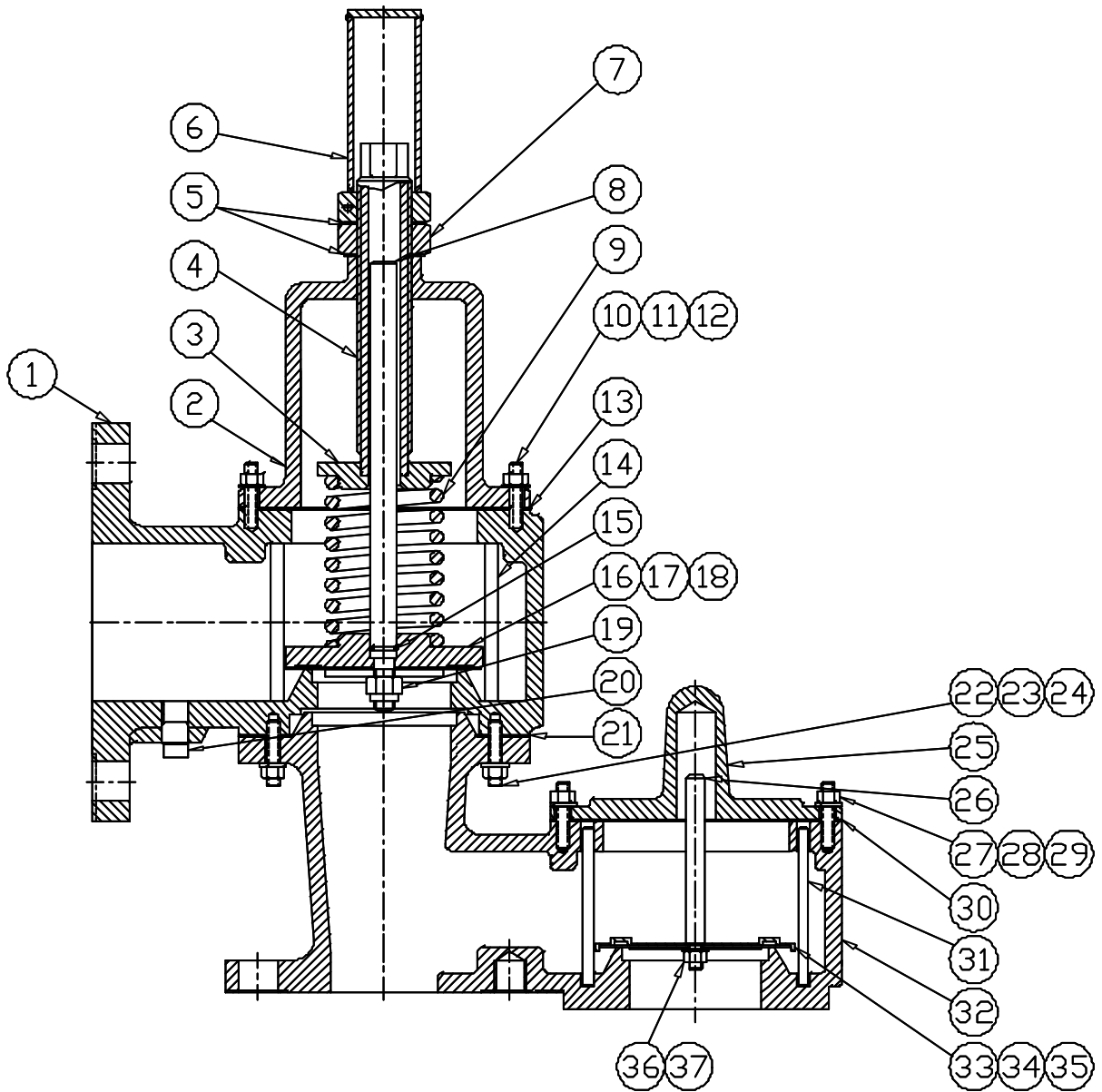

ITEM	DESCRIPTION	CARBON	ALUMINUM	STAINLESS
1	Outlet	CS	Aluminum	316 SS
2	Spring Chamber	CS	Aluminum	316 SS
3	Spring Button	CS	CS	316 SS
4	Adjustment Screw	SS	SS	SS
5	Gasket, Cap *	SS	SS	SS
6	Cap	CS	CS	316 SS
7	Hex Jam Nut	CS	CS	SS
8	Stem	316 SS	316 SS	316 SS
9	Spring	CS	CS	SS
10	Stud	CS	CS	316 SS
11	Lock Washer	CS	CS	316SS
12	Hex Nut	CS	CS	316 SS
13	Gasket- Spring Chamber *	Non-Asb	Non-Asb	Non-Asb
14	Guide Post	316 SS	316 SS	316 SS
15	O-Ring *	Viton	Viton	Viton
16	Pallet	316 SS	316 SS	316 SS
17	Diaphragm *	Teflon®	Teflon®	Teflon®
18	Retainer Plate	316 SS	316 SS	316 SS
19	Hex Lock Nut	316 SS	316 SS	316 SS
20	Plug	CS	CS	SS
21	Gasket *	Teflon®	Teflon®	Teflon®
22	Stud	CS	CS	316SS
23	Lock Washer	CS	CS	316SS
24	Hex Nut	CS	CS	316 SS
25	Vent Cover - Vac	CS	Aluminum	316 SS
26	Stem - Vac	316 SS	316 SS	316 SS
27	Stud	CS	CS	316SS
28	Lock Washer	CS	CS	316SS
29	Hex Nut	CS	CS	316 SS
30	Gasket-Cover, Vac *	Teflon®	Teflon®	Teflon®
31	Guide Post - Vac	316 SS	316 SS	316 SS
32	Body	CS	Aluminum	316 SS
33	Pallet - Vac	316 SS	316 SS	316 SS
34	Diaphragm - Vac *	Teflon®	Teflon®	Teflon®
35	Retainer Plate - Vac	316 SS	316 SS	316 SS
36	Lock Washer	316 SS	316 SS	316 SS
37	Hex Nut	316 SS	316 SS	316 SS
38	O-Ring, (Machined Pallet) * #	Viton	Viton	Viton

* = Recommended Spare Parts

= See Figure 2 Item 39

Groth Model 1261A Pressure/Vacuum Relief Valve

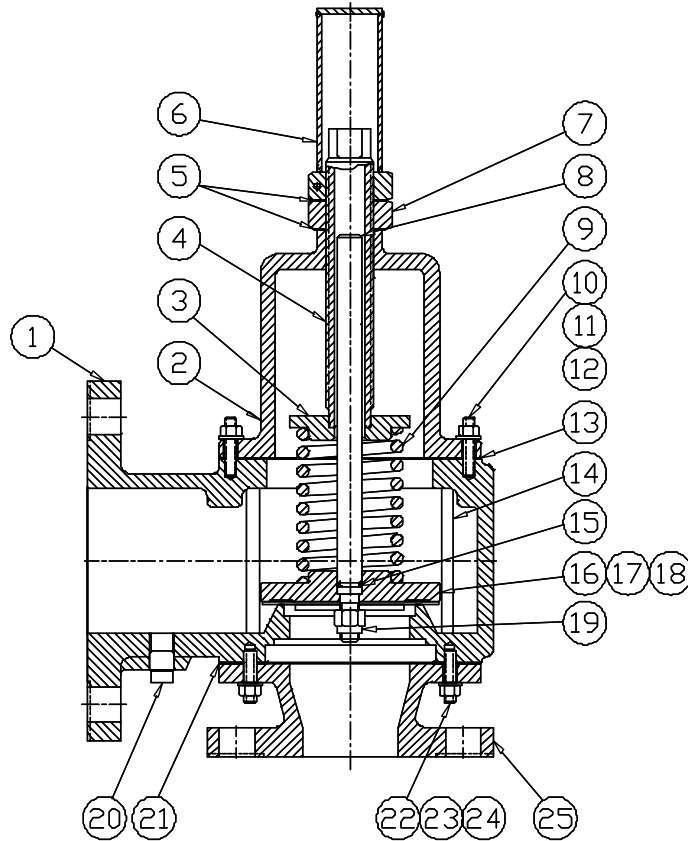

ITEM	DESCRIPTION	CARBON	ALUMINUM	STAINLESS
1	Outlet	CS	Aluminum	316 SS
2	Spring Chamber	CS	Aluminum	316 SS
3	Spring Button	CS	CS	316 SS
4	Adjustment Screw	SS	SS	SS
5	Gasket, Cap *	SS	SS	SS
6	Cap	CS	CS	316 SS
7	Hex Jam Nut	CS	CS	SS
8	Stem	316 SS	316 SS	316 SS
9	Spring	CS	CS	SS
10	Stud	CS	CS	316 SS
11	Lock Washer	CS	CS	316SS
12	Hex Nut	CS	CS	316 SS
13	Gasket- Spring Chamber *	Teflon®	Teflon®	Teflon®
14	Guide Post	316 SS	316 SS	316 SS
15	O-Ring *	Viton	Viton	Viton
16	Pallet	316 SS	316 SS	316 SS
17	Diaphragm *	Teflon®	Teflon®	Teflon®
18	Retainer Plate	316 SS	316 SS	316 SS
19	Hex Lock Nut	316 SS	316 SS	316 SS
20	Plug	CS	CS	SS
21	Gasket- Inlet *	Teflon®	Teflon®	Teflon®
22	Stud	CS	CS	316SS
23	Lock Washer	CS	CS	316SS
24	Hex Nut	CS	CS	316 SS
25	Inlet	CS	Aluminum	316 SS

* = Recommended Spare Parts

Groth Model 1301A Vacuum Relief Valve

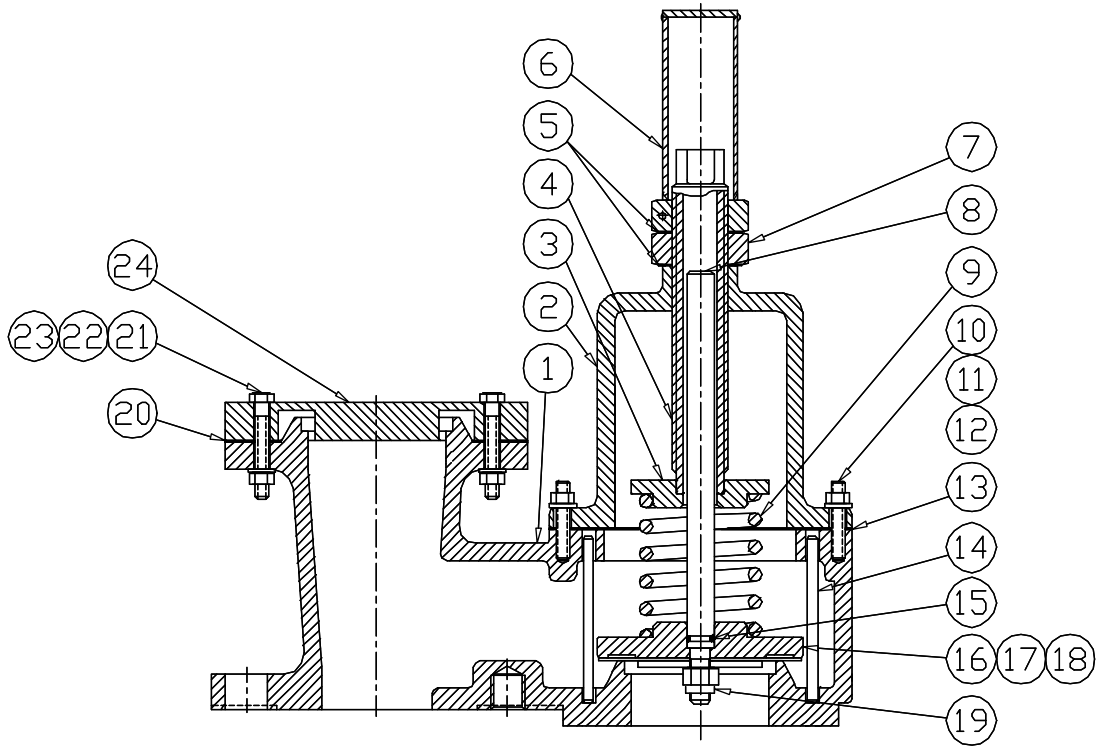

ITEM	DESCRIPTION	CARBON	ALUMINUM	STAINLESS
1	Body	CS	Aluminum	316 SS
2	Spring Chamber	CS	Aluminum	316 SS
3	Spring Button	CS	CS	316 SS
4	Adjustment Screw	SS	SS	SS
5	Gasket, Cap *	SS	SS	SS
6	Cap	CS	CS	316 SS
7	Hex Jam Nut	CS	CS	SS
8	Stem	316 SS	316 SS	316 SS
9	Spring	CS	CS	SS
10	Stud	CS	CS	316 SS
11	Lock Washer	CS	CS	316SS
12	Hex Nut	CS	CS	316 SS
13	Gasket- Spring Chamber *	Teflon®	Teflon®	Teflon®
14	Guide Post	316 SS	316 SS	316 SS
15	O-Ring *	Viton	Viton	Viton
16	Pallet	316 SS	316 SS	316 SS
17	Diaphragm *	Teflon®	Teflon®	Teflon®
18	Retainer Plate	316 SS	316 SS	316 SS
19	Hex Lock Nut	316 SS	316 SS	316 SS
20	Gasket- Cover *	Teflon®	Teflon®	Teflon®
21	Hex Bolt	CS	CS	316SS
22	Lock Washer	CS	CS	316SS
23	Hex Nut	CS	CS	316 SS
24	Cover	CS	CS	316 SS

* = Recommended Spare Parts

Groth Model 1361A Vacuum Relief Valve

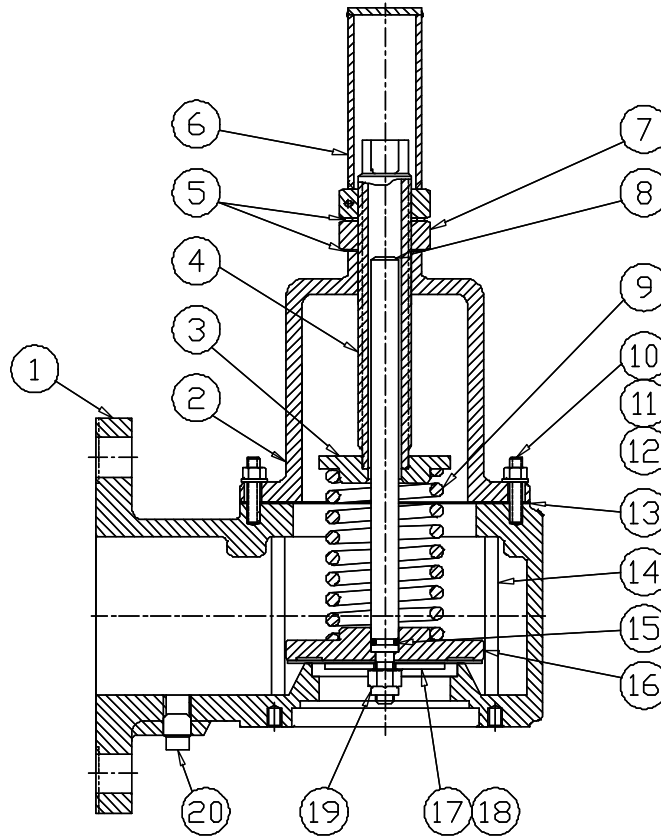

ITEM	DESCRIPTION	CARBON	ALUMINUM	STAINLESS
1	Outlet	CS	Aluminum	316 SS
2	Spring Chamber	CS	Aluminum	316 SS
3	Spring Button	CS	CS	316 SS
4	Adjustment Screw	SS	SS	SS
5	Gasket, Cap *	SS	SS	SS
6	Cap	CS	CS	316 SS
7	Hex Jam Nut	CS	CS	SS
8	Stem	316 SS	316 SS	316 SS
9	Spring	CS	CS	SS
10	Stud	CS	CS	316 SS
11	Lock Washer	CS	CS	316SS
12	Hex Nut	CS	CS	316 SS
13	Gasket *	Teflon®	Teflon®	Teflon®
14	Guide Post	316 SS	316 SS	316 SS
15	O-Ring *	Viton	Viton	Viton
16	Pallet	316 SS	316 SS	316 SS
17	Diaphragm *	Teflon®	Teflon®	Teflon®
18	Retainer Plate	316 SS	316 SS	316 SS
19	Hex Lock Nut	316 SS	316 SS	316 SS
20	Plug	CS	CS	SS

* = Recommended Spare Parts

Groth Model 2301A Pressure Relief Valve

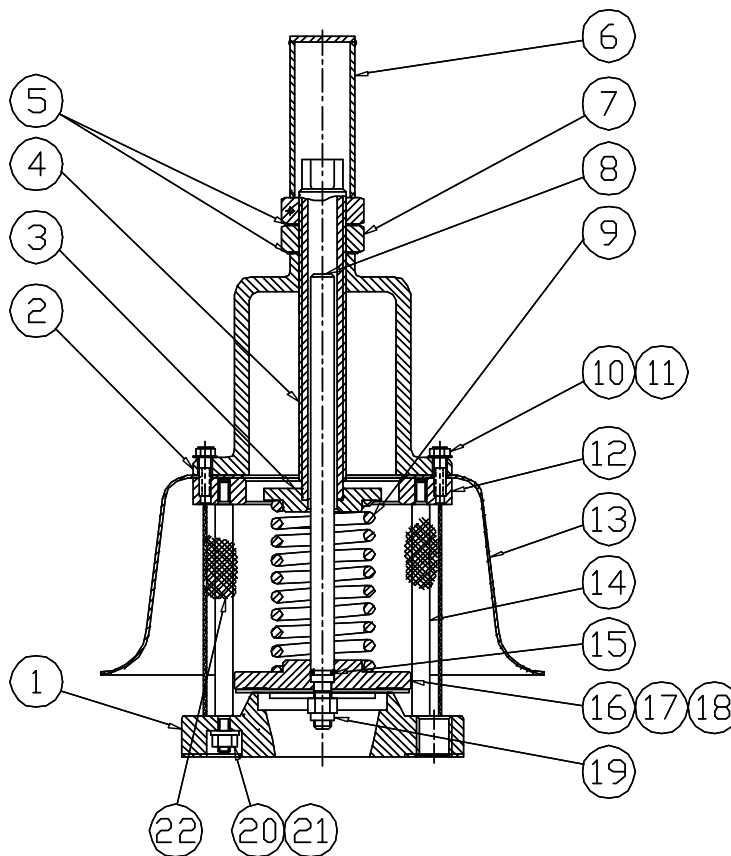

ITEM	DESCRIPTION	CARBON	ALUMINUM	STAINLESS
1	Base	CS	Aluminum	316 SS
2	Spring Chamber	CS	Aluminum	316 SS
3	Spring Button	CS	CS	316 SS
4	Adjustment Screw	SS	SS	SS
5	Gasket, Cap *	SS	SS	SS
6	Cap	CS	CS	316 SS
7	Hex Jam Nut	CS	CS	SS
8	Stem	316 SS	316 SS	316 SS
9	Spring	CS	CS	SS
10	Hex Bolt	CS	CS	316 SS
11	Lock Washer	CS	CS	316SS
12	Support Ring	CS	CS	316 SS
13	Weatherhood	CS	Aluminum	316 SS
14	Weatherhood Post	316 SS	316 SS	316 SS
15	O-Ring *	Viton	Viton	Viton
16	Pallet	316 SS	316 SS	316 SS
17	Diaphragm *	Teflon®	Teflon®	Teflon®
18	Retainer Plate	316 SS	316 SS	316 SS
19	Hex Lock Nut	316 SS	316 SS	316 SS
20	Lock Washer	CS	CS	316SS
21	Hex Nut	CS	CS	316SS
22	Screen	SS	SS	316 SS

* = Recommended Spare Parts

MODEL INFORMATION

The nameplate on the Valve contains the Model Number, Serial Number, set pressures and flow capacity at a specified over-pressure. The Model Number contains additional information about materials of construction, soft goods and options. The following chart will assist in relating the Model Number to the characteristics of your valve:

MODEL	SIZE	MATERIAL	OPTIONS
1201B	02"	Pallet	Z =Special Options
1202B	03"	Seat	O =No Specials
1203A	04"	Body	
1221B	06"		J = Steam Jacket
1222B	08"	1 =Aluminum	O = No Jacket
1223A	10"	3 =Carbon Steel	
1261A	12"	5 =316 SS	
1301A		Z = Special	SEAT MATERIAL
1361A			B = Buna-N
2301A			T = Teflon®
			V = Viton
			M = Metal-to-Metal
			Z = Special

Teflon® is the registered trademark of the Du Pont Company.

EXAMPLE: 1221A-02-355-TOO indicates a 2" Model 1221A with Carbon Steel body, 316SS seat and pallet, Teflon□ seat diaphragms and no special options.

PRODUCT LIMITED WARRANTY

Only Groth's Product Limited Warranty terms apply to purchase orders accepted by Groth Corporation.

- A. Seller warrants that products that are manufactured by Seller are manufactured in accordance with published specifications and free from defects in materials and/or workmanship for a period of (12) twelve months. Seller, at its option, will repair or replace any products returned intact to the factory, transportation charges prepaid, which Seller, upon inspection, determines to be defective in material and/or workmanship. The foregoing shall constitute the sole remedy for any breach of Seller's warranty.
- B. THERE ARE NO UNDERSTANDINGS, AGREEMENTS, REPRESENTATIONS, OR WARRANTIES, EXPRESS OR IMPLIED (INCLUDING MERCHANTABILITY OR FITNESS FOR A PARTICULAR PURPOSE REGARDING PRODUCTS) UNLESS SPECIFIED IN THE SALES CONTRACT. THIS CONTRACT STATES THE ENTIRE OBLIGATION OF SELLER. Seller makes no warranties, either express or implied, except as provided herein, including without limitation thereof, warranties as to marketability, merchantability, for a particular purpose or use, or against infringement of any patent of products. In no event shall Seller be liable for any direct, incidental or consequential damages of any nature, or losses or expenses resulting from any defective new product or the use of any such product, including any damages for loss of time, inconvenience, or loss of use of any such product.
- C. The original Manufacturer shall be solely responsible for the design, development, supply, production, and performance of its products hereunder, and the protection of its trade name or names, if any. It assumes no responsibility, for products modified or changed by its agent or customer, or any other third party. Any such modifications or changes to products sold by Seller hereunder shall make the product limited warranty null and void.
- D. Groth assumes no responsibility for products modified or changed by Customer or any other third party. Any such modifications or changes to products sold by Groth hereunder shall make the product limited warranty null and void. Groth shall be under no obligation to manufacture, sell or supply, or to continue to manufacture, sell, or supply any of the products.