

# TABLE OF CONTENTS:

<b>INTRODUCTION:</b>	3
<b>DESIGN, FUNCTION &amp; OPERATION</b>	4
<b>GENERAL SAFETY INSTRUCTIONS</b>	5
<b>SAFETY WARNINGS</b>	5
<b>INSPECTION AND INSTALLATION</b>	6
<b>PREVENTIVE MAINTENANCE</b>	7
<b>MODEL 2000A DISASSEMBLY &amp; ASSEMBLY</b>	8
<b>MODEL 2000A DISASSEMBLY &amp; ASSEMBLY</b>	8
<b>MODEL 2050A DISASSEMBLY &amp; ASSEMBLY</b>	9
<b>MODEL 2400A DISASSEMBLY &amp; ASSEMBLY</b>	13
<b>MODEL 2450A DISASSEMBLY &amp; ASSEMBLY</b>	14
<b>TESTING AND SETTING PROCEDURE</b>	18
<b>MODEL INFORMATION</b>	13
<b>PRODUCT LIMITED WARRANTY</b>	13

## INTRODUCTION:

**Groth's Emergency Relief Valve (ERV)** is designed to provide emergency relief capacity beyond that furnished by the normal operating pressure relief valve on the tank. They are used on liquid storage tanks and other process vessels or systems to prevent structural damage due to excess internal pressure or vacuum that could result under emergency situations due to fire exposure or failure of the inert gas blanketing system.

Storage tanks are pressurized when liquid is pumped in, compressing the existing vapor or when increasing temperature causes increased evaporation or expansion of existing vapor. Conversely, vacuum may be created when pumping out or due to decreasing temperature. To prevent damage, vapor must be allowed to escape or enter the tank at a specified pressure or vacuum condition. The volume rate of venting depends upon the tank size, volatility of the contents, the pumping rate and the temperature. See API Standard 2000 for the procedures to determine venting requirements.

The valves are designed to be self closing under normal operation. As excessive pressure builds up, the valve relieves and then reseats when over pressure has been dissipated. Some models have a restraining cable to connect the head and flanges and also serve as a grounding cable.

The pallets include Groth's special "cushioned air" seating. Teflon® (FEP) seating diaphragms are standard; they minimize sticking caused by resinous vapors and atmospheric moisture. Diaphragms are also available in Buna-N, Viton and other elastomers. Peripheral guides insure proper alignment and integrity of the seating.

The ERVs are preset at the factory in accordance with the purchase order's instructions. These settings are printed on the stainless steel name tag.

The valve must be maintained by a knowledgeable valve technician. It should only be assembled under clean conditions preferably in a shop environment. Carefully read and understand this Manual before installing or repairing this valve.

For information not contained in this manual, please contact:

Groth Corporation  
13650 N. Promenade Blvd  
Stafford, TX 77477  
281-295-6800 (Phone)  
281-295-6995 (Fax)

## DESIGN, FUNCTION & OPERATION

The 2000A Series was designed as a cost effective valve that would protect a tank by providing emergency pressure relief caused by fire or other factors that could make the pressure rise. Groth manufactures four models in this series [Table 1] for pressure relief; two models also provide vacuum relief.

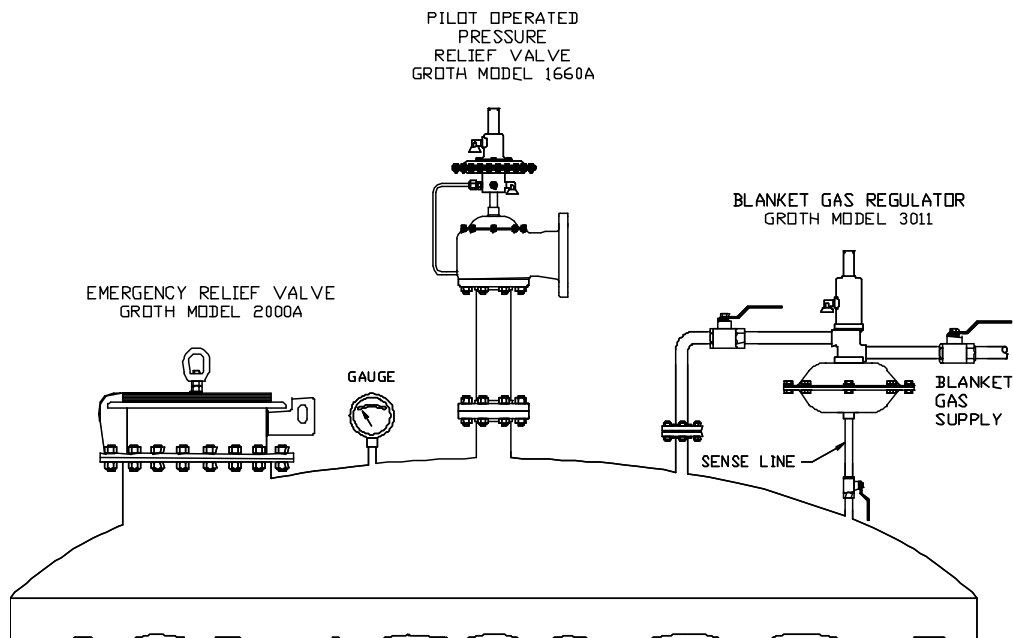
Table 1 : Model Identification			
Model	Pressure	Vacuum	Description
2000A	Y		Guided Cover
2050A	Y	Y	Guided Cover w/ vacuum relief
2400A	Y		Hinged Cover
2450A	Y	Y	Hinged Cover w/ vacuum relief

Model 2000A provides pressure relief only; vacuum relief must be supplied by a separate breather valve. Model 2050A provides pressure relief and vacuum relief through a spring loaded port integral to the cover assembly. A weatherhood and screen are provided for protection.

Model 2400A incorporates a hinged pivot point for the cover, providing additional alignment for the cover so it reseats properly after venting. The Model 2450A adds vacuum relief capability while keeping the hinge design. The hinged design closes after relieving pressure or vacuum.

All valve covers can be lifted off the base, providing quick access for tank inspection and maintenance. *Note: Depending on pressure setting, it may be necessary to use a crane or other lifting device to open or remove the cover assembly.* A typical tank installation is shown in Figure 1 which includes a Pilot Operated Pressure/Vacuum Relief Valve, a Gas Blanketing Regulator and the 2000A Emergency Relief Valve which provides emergency pressure relief. Groth Corporation manufactures all of these devices.

**Figure 1: Tank Installation - Safety Equipment**



## GENERAL SAFETY INSTRUCTIONS

This section is an overview of safety guidelines that should be followed during the installation, operation and maintenance of Groth Pressure / Vacuum Relief Valves. To understand the context of these instructions and warnings, it is necessary to completely read and understand the contents of this manual.

The purpose of a pressure/vacuum relief valve is to prevent excessive pressure or vacuum in a tank or process system. The valve must be designed for the proper MAWP and flow requirements of the system. Consult API Standard 2000 for tank protection sizing procedures. An improperly specified or functioning relief valve may result in structural damage to the tank or system, and can cause severe personal injury or death.

## SAFETY WARNINGS

**THE PURPOSE OF AN EMERGENCY RELIEF VALVE (ERV) IS TO PREVENT EXCESSIVE PRESSURE IN A TANK OR PROCESS SYSTEM UNDER EMERGENCY SITUATIONS. THE VALVE MUST BE DESIGNED FOR THE PROPER MAWP AND FLOW REQUIREMENTS OF THE SYSTEM. CONSULT API STANDARD 2000 FOR TANK PROTECTION SIZING PROCEDURES. AN IMPROPERLY SPECIFIED OR FUNCTIONING EMERGENCY RELIEF VALVE MAY RESULT IN STRUCTURAL DAMAGE TO THE TANK OR SYSTEM AND SEVERE PERSONAL INJURY OR DEATH.**

**THE ERV SET PRESSURE AND SET VACUUM ARE SET AT THE FACTORY PER PURCHASE ORDER SPECIFICATIONS. THE SET PRESSURE AND NOMINAL FLOW CAPACITY ARE STAMPED ON THE VALVE NAMEPLATE. DO NOT ATTEMPT TO READJUST THE SET PRESSURE. DO NOT CHANGE PRESSURE RATING BY ADDING ADDITIONAL WEIGHTS TO THE PALLET ASSEMBLY WITHOUT CONSULTING FACTORY. ADDING MORE WEIGHTS THAN RECOMMENDED WILL RESULT IN AN INCREASE IN SETTING.**

**DO NOT ATTEMPT TO LIFT PALLET ASSEMBLIES BY HAND. THESE ASSEMBLIES CAN WEIGHT IN EXCESS OF 400 LBS. AND COULD CAUSE BODILY INJURY WITHOUT THE USE OF AN EXTERNAL LIFTING METHOD.**

**MODEL 2000A AND 2050A VALVES WILL LIKELY NOT RESEAT AFTER A SIGNIFICANT OVER-PRESSURE CONDITION. IF THIS IS NOT ACCEPTABLE, IT IS RECOMMENDED TO USE EITHER MODEL 2400A OR 2450A.**

**EMERGENCY RELIEF VALVES ARE DESIGNED TO PROVIDE FULL RATED CAPACITY AT 100% OVER-PRESSURE. IF THE VALVE IS TO BE OPERATED AT A REDUCED OVER-PRESSURE, CONSULT FACTORY FOR ACTUAL FLOW CAPACITY UNDER SPECIFIED CONDITIONS.**

**DO NOT MIX PALLET ASSEMBLIES FROM DIFFERENT VALVES. FAILURES TO ENSURE THAT THE PALLET ASSEMBLIES ARE INSTALLED IN THE ORIGINAL AND CORRECT LOCATION CAN CHANGE THE PRESSURE OR VACUUM RELIEF SETTINGS. THIS CAN CAUSE A TANK FAILURE.**

**DO NOT LOOSEN HEX NUTS UNTIL ALL SPRING COMPRESSION HAS BEEN RELEASED. SPRING PRE-LOAD IS SUBSTANTIAL AND COULD CAUSE SEVERE PERSONAL INJURY IF FASTENERS WERE REMOVED WITH THE SPRING COMPRESSED.**

**DO NOT ATTEMPT TO REMOVE THE VALVE FROM THE TANK OR PROCESS VESSEL WITHOUT FIRST BLEEDING ALL PRESSURE FROM THE SYSTEM. ALTERNATIVE MEANS OF PRESSURE RELIEF MUST BE PROVIDED WHEN THE VALVE IS OUT OF SERVICE.**

**THE VALVE HAS BEEN EXPOSED TO PROCESS VAPORS WHILE IN SERVICE. OBSERVE ALL PLANT PROCEDURES AND MATERIAL SAFETY DATA SHEETS (MSDS) FOR THE PRODUCTS IN THE SYSTEM WHEN INSPECTING, ADJUSTING OR SERVICING THE VALVE. TAKE APPROPRIATE SAFETY PRECAUTIONS REGARDING EYE PROTECTION, RESPIRATION AND SKIN CONTACT.**

**DO NOT ADD ANY WEIGHT TO THE PALLET ASSEMBLY, CHANGE THE ADJUSTMENT SCREW (CHANGING SET PRESSURE OR VACUUM), OR CHANGE PALLET STEM WITHOUT FIRST CONSIDERING THE ALLOWABLE TANK PRESSURE OR WITHOUT MEASURING DESIGN LIFT TO ENSURE THE LIFT IS NOT RESTRICTED. RESTRICTING VALVE LIFT COULD "CHOKE" THE VALVE AND NOT ALLOW FOR FULL RATED CAPACITY. CHANGING THE WEIGHT OR ADJUSTMENT OF A SPRING COULD ALSO RESTRICT THE LIFT OF A VALVE AT A SPECIFIED OVERPRESSURE, REDUCING THE RATED CAPACITY OF THE VALVE. UNDER THESE CONDITIONS, THE VALVE WILL NOT PROTECT THE TANK FROM RUPTURING DUE TO CHANGES IN INTERNAL PRESSURE. TANK FAILURE CAN CAUSE MATERIAL DAMAGE AND LOSS AND RESULT IN SEVERE PERSONAL INJURY OR DEATH.**

**THE ERV IS EQUIPPED WITH A GROUND STRAP TO PREVENT STATIC ELECTRIC DISCHARGE. THIS STRAP MUST BE SECURED TO A PROPER GROUND WHILE ALLOWING VALVE OPERATION. IF THIS STRAP IS IMPROPERLY GROUNDED, STATIC DISCHARGE COULD CAUSE TANK RUPTURE AND RESULT IN SEVERE INJURY OR DEATH.**

## INSPECTION AND INSTALLATION

The ERV is packed and supported to prevent damage or contamination during shipping. It should be similarly protected during subsequent handling and storage. Before installation inspect the unit visually. If there are indications of physical damage or internal contamination, the valve must be disassembled, cleaned and inspected before installation.

Inspect the valve for any sign of damage that may have occurred in shipment and report this to the carrier. The seat protector (rubber strip placed over the valve seat) shall be removed before placing the valve into service.

Handles/Eye Nuts are provided on the upper weight plates for handling the pallet assembly. The body has three lifting eyes that are used to lift and position the body. To avoid damage to the lower flange surface, set the valve on a soft clean gasket material until it is ready to be installed. It should be stored in a clean environment until it is to be mounted on the tank.

The 2000A Series Emergency Relief Valve is a device that must be handled carefully to ensure seat tightness. The body is manufactured from thin steel plate material and can be damaged by over-tightening the studs or mounting on a tank nozzle that is not flat. The valve is also equipped with a grounding strap that should be grounded properly to prevent static electric discharge.

The standard bodies are furnished with flat flanges; the valve should be mounted on a flat faced 150# ANSI or API 650 flange. It is recommended to use a full faced gasket to avoid deflecting the body flange. The connecting flanges must be flat within 0.015" and clean, free of scratches, corrosion and tool marks.

All valves should be installed using the three body lifting lugs. Mount the valve with the pallet assembly in the horizontal plane.

1. Begin by inspecting the gasket; make sure that the material is suitable for the service. Gasket dimensions are listed in Table 2 below:
2. Lubricate all studs and nuts with an appropriate thread lubricant. If stainless steel fasteners are used, select an anti-seize lubricant such as moly-disulfide.
3. Align the gasket with the bolt circle.
4. Set the valve body carefully on the nozzle; keep the gasket between the flanges. Install the studs and tighten nuts hand tight.
5. Torque all fasteners to half the recommended value (see Table 3) in a staggered, alternating pattern or follow appropriate plant maintenance guidelines and standards.  
*\*Note: Torque values are based on a gasket factor  $m=3.5$ , gasket factor  $y=2000$  psi, maximum pressure = 2 psi.*
6. Make sure that the flanges are not distorted and that the gasket is evenly compressed.
7. Make up the final torque and check that no further nut rotation occurs.
8. For Model 2000A and Model 2050A, the cover assembly may be independently lifted into position by using the handles/eye nuts supplied for the weight plates. Align the pallet assembly peripheral guides with the body bore and carefully lower the cover assembly until it seats against the body.

**Table 2: Body Flange Gasket Dimensions**

Type Flange	O.D. (in)	I.D. (in)	B.C. (in)	Hole (in)	Qty.
FF 16" – 150 #	23.50	15.25	21.25	1.13	16
FF 20" – 150 #	27.50	19.25	25.00	1.25	20
FF 24" – 150 #	32.00	23.25	29.50	1.38	20
FF 20" – API 650	26.00	19.25	23.50	.75	16
FF 24" – API 650	30.00	23.25	27.50	.75	20

Table 3: Recommended Torque Values*					
	Size	Qty Holes	Bolt (in) (UNC)	Torque (ft-lbs)	
				Raised Face	Flange Face
150 ANSI	16"	16	1.000	52	104
	20"	20	1.125	63	110
	24"	20	1.250	86	148
API650	20"	20	0.625	35	53
	24"	20	0.625	43	61

## PREVENTIVE MAINTENANCE

The 2000A Series valves do not require routine lubrication or adjustments, but should be checked periodically, at least twice a year, to confirm that the valve is functioning properly.

Because these valves provide emergency protection, they will not normally cycle in service. Inspection of seat tightness should be done to ensure compliance with local air pollution control requirements as needed. When inspecting the diaphragms, gaskets and seals should also be checked. Please refer to handling instructions listed in the Installation section of this manual. Always keep records of maintenance performed.

### WARNING

*If the valve must be removed from the tank for any reason, make sure that all pressure has been released before the flange fasteners are loosened. Refer to your company procedures before venting the tank pressure and when handling toxic or otherwise hazardous materials.*

*The main valve body, gaskets and all other components are exposed to the process vapor. Observe all standard safety precautions as specified on Material Safety Data Sheets for the product[s] in the system while removing the valve and when repairing it. Take appropriate safety precautions regarding eye protection, respiration & skin contact.*

The table below shows the various configurations that make up a 2000A Series valve. Identify the valve, and read the appropriate section.

Models	Page	Guided Cover	Hinged Cover	Vacuum Assembly
2000A	8	X		
2050A	9	X		X
2400A	13		X	
2450A	14		X	X

Each section will describe the disassembly and assembly procedures. Each section references part numbers for that valve only. Use the diagrams preceding each section.

Inspect the soft goods, the seat, and the flanges to ensure seal tightness. Replace components as necessary.

### SOFT GOODS KITS

A soft goods kit consists of the diaphragms and washers, if needed. The following system is used to identify and order kits:

**Table 5: 2000 Series – Soft Good Kits Numbering System**

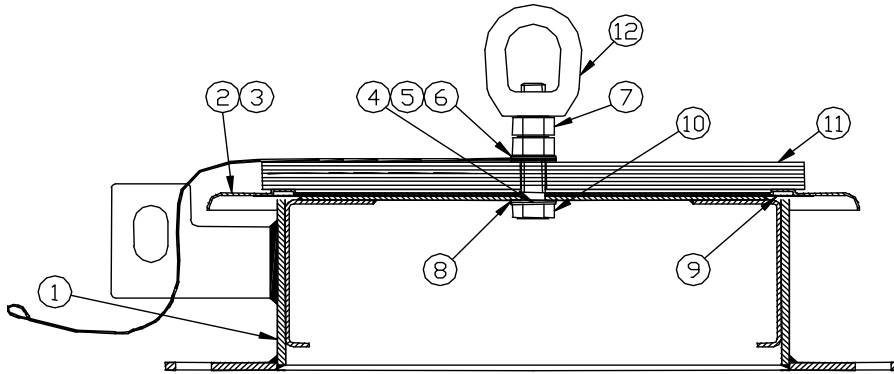
Prefix	Model No.	Size	Soft Good Material
KS	2000 = 2000A	16 = 16"	A = Aflas
	2050 = 2050A	20 = 20"	B = Buna-n
	2400 = 2400A	24 = 24"	K = Kalrez
	2450 = 2450A		T = Teflon V = Viton

*Note: Soft goods for the 2000 and 2000A Model Series are interchangeable.*

### Example:

**KS200016T – A Soft goods kit for a 16"2000 valve made of Teflon.**

## MODEL 2000A DISASSEMBLY & ASSEMBLY



ITEM	DESCRIPTION
1	Body
2	Pallet
3	Retainer Plate
4	Flat Washer, 3/4", SS
5	Ground Cable
6	Sleeve

ITEM	DESCRIPTION
7	Hex Nut, 3/4"-10 UNC
8	Washer, 3/4", PTFE
9	Diaphragm
10	Hex Bolt, 3/4"-10 UNC
11	Weight Plate(s)*
12	Eye Nut*

\* Not used on valves with low settings

### 2000A Disassembly

1. Read "Warning" sections on page 5. Remove the valve from the tank.
2. Using the eye nut [12], or the edges of the pallet, lift vertically. Set the cover on a short length of pipe (minimum 6" high). This will elevate the retainer plate peripheral guides above the table so they aren't bent or damaged.
3. Place the assembly with the 3/4" hex bolt in a vise, or use a wrench to hold the center bolt from the bottom side. Loosen the hex nuts and remove. Lift the weight plate [11], pallet [2], and diaphragms [9].

### 2000A Assembly

1. Prior to final assembly, verify that the body seat area is free of corrosion, damage or product build-up. The seat should be carefully cleaned, if necessary.

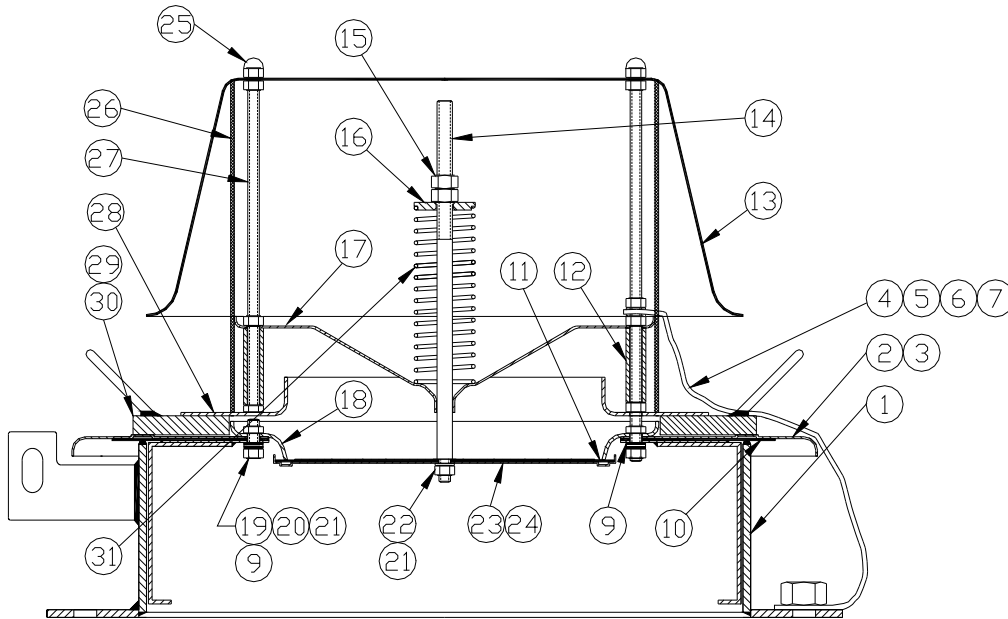
**NOTE: If the seat is damaged it must be lapped using a perfectly flat ground metal disc. Wipe seating surface clean before proceeding. Soft goods should normally be replaced whenever valve maintenance is performed.**

2. Reverse the steps of Disassembly, starting with the retainer and cover. If a diaphragm is an elastomer, place it between the Teflon diaphragm and the retainer plate. See Figure 3b.

**NOTE: When replacing the ground cable, surface corrosion must be completely cleaned to allow cable to ground pallet to tank nozzle.**

3. The valve should be tested on a pressure test stand to verify the settings and evaluate seat tightness follow instructions on page 19. Mount valve on tank; see Installation on page 6.

## MODEL 2050A DISASSEMBLY & ASSEMBLY



ITEM	DESCRIPTION
1	Body
2	Pallet – Pressure
3	Retainer Plate – Pressure
4	Flat Washer, 3/8", SS
5	Ground Cable
6	Sleeve
7	Hex Nut, 3/8"-16 UNC
8	N/A
9	Flat Washer, 3/8", PTFE
10	Diaphragm – Pressure
11	Diaphragm – Vacuum
12	Spacer
13	Weatherhood
14	Stem – Vacuum
15	Hex Nut, 1/2"-13 UNC
16	Spring Button

ITEM	DESCRIPTION
17	Stem Guide
18	Seat – Vacuum
19	Hex Bolt, 3/8"-16 UNC
20	Flat Washer, 3/8", SS
21	Hex Nut, 3/8"-16 UNC
22	Lock Washer, 3/8"
23	Pallet – Vacuum
24	Retainer Plate – Vacuum
25	Crown Nut, 3/8"-16 UNC
26	Screen
27	Weatherhood Post
28	Water Dam*
29	Weight Plate*
30	Handle*
31	Spring

\* Not used on valves with low settings.

### 2050A Disassembly

1. Read "Warning" sections on page 5. Remove the valve from the tank.
2. Lift pressure/vacuum pallet [2] assembly from body [1].
3. Using the handles [30] on the weight plate [29], or the edges of the pallet, lift vertically. Set the cover on three evenly spaced support blocks (Figure 6). This will elevate the retainer plate peripheral guides above the table so they aren't bent or damaged.
4. Remove nuts [25], lift weatherhood [13], bird screen [26] and set aside. Remove the nut holding the ground cable [5], and remove the cable.
5. Record "A" dimension (Figure 7). Place a short length of pipe (minimum 6" high) beneath the vacuum pallet [23] to prevent it from falling. Back the top nut [15] completely off the stem. Compress the spring using the spring button [16] and grasp the stem (Figure 8). **Caution: Remove the second**

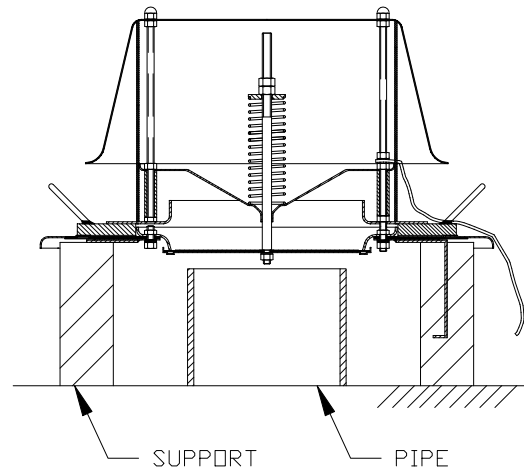
**nut from the stem. Slowly raise the spring button to release the spring compression. The spring force will be in 5 – 30 lb range, depending on vacuum setting.**

6. Using weight plate handles, if included, lift pressure pallet [2] with attached assembly and remove vacuum pallet-stem [23, 14] assembly from the bottom.
7. Remove the nuts on the weatherhood posts holding the stem guide [17]. Note: For low pressure settings, a weight plate is added on the stem guide [17].
8. Lift the spacers [12]. Remove the nuts above the water dam [28]. Note: Water dam is only used if weight plate is mounted directly on pressure pallet [2].
9. Remove the weatherhood posts [27] by loosening the nuts beneath the pallet.
10. Carefully lift the weight plate [29] vertically.  
**Caution: This may require a crane due to the weight. (See Warning on page 5.)**
11. Turn pallet assembly upside down (Figure 9).
12. Remove remaining bolts, nuts, and washers [7, 9, 19, 20, 21] to separate the vacuum seat.
13. Lift the retainer plate [3] and diaphragms [10] from the pressure pallet.

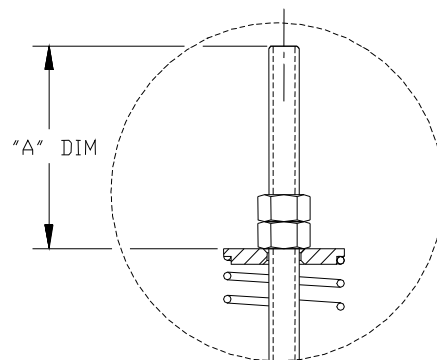
2050A Assembly

Rebuild the valve reversing the disassembly steps.

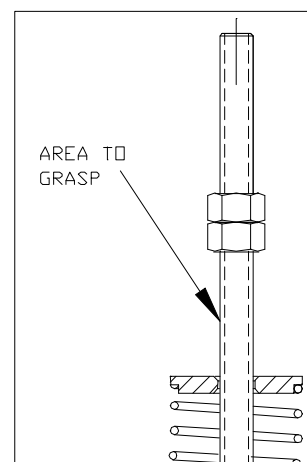
1. Begin by placing the pallet [2] upside down on support blocks evenly spaced or on a pipe.
2. Wipe clean “air cushion” groove (seat area) in pallet.
3. Center diaphragms [10] (qty 2) on pallet. See *Figure 3 for orientation of diaphragms, if elastomer is used.*
4. Place retainer plate [3], align with pallet hole pattern.



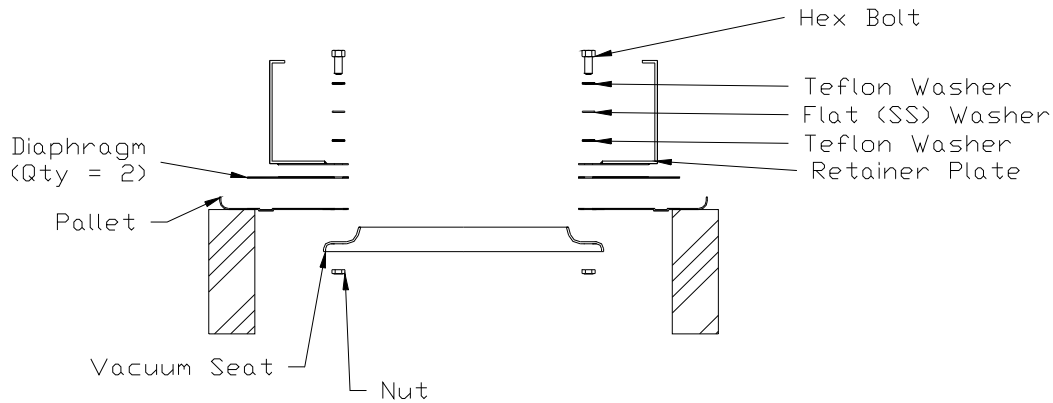
**Figure 6 : Pallet Support (2050A)**



**Figure 7 : Vacuum Spring Compression**

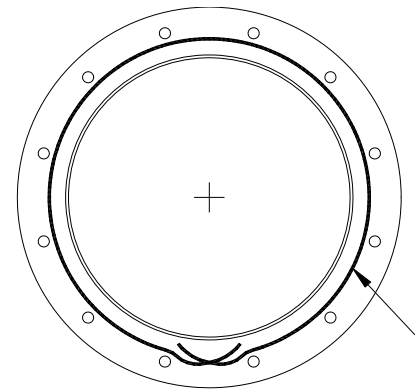


**Figure 8 : Loosening Nuts for Spring**



**Figure 9 : Exploded View of Pallet Assembly (Upside Down)**

5. Apply PTFE sealant tape around the inside hole pattern of the vacuum seat [18] (Figure 10). Tape should be at least 1/16" thick. *Note: Other sealants (such as Silicone) can replace the Teflon tape if compatible with tank products.*
6. Position the vacuum seat [18] as shown from beneath the pallet.
7. Align vacuum seat with pallet and insert 4 bolts (at 90 degrees from each other) from the top using fasteners shown in Figure 9 [7, 19, 20, 21].



**Figure 10 : Sealant tape on Vacuum Seat**

8. Insert four more bolts, leaving four holes, at 90 degrees from each other, open. The weatherhood posts are installed in these holes.
9. Turn pallet assembly right side up, and place on support blocks again.
10. Run 3/8" hex nut up 1 1/2" from end on all thread and insert weatherhood posts [27] in remaining holes. A Teflon washer, flat washer and nut are installed from the bottom. Allow approximately 2 threads past the nut to be free. The four weatherhood posts should all extend approximately 11.13" above the pallet.
11. Lower the weight plate [29] (if needed for setting).
12. Use a sealant tape around the inner edge of the weight plate. *Note: Other sealants (such as Silicone) can replace the Teflon tape if compatible with tank products.*
13. Insert the waterdam [28] using the weatherhood posts [27] as a guide. Use sealant tape on bottom side, outside of its hole pattern. Tighten nuts. **Note: Do not over-tighten. It is suggested to first hand tighten the nuts, torque 15 ft-lbs in an alternating criss-cross pattern.**
14. Insert the spacers [12], and the stem guide [17]. Tighten nut to retain to pallet assembly.
15. If pallet assembly is high enough from the table, insert vacuum pallet-stem [23, 24, 14] assembly from beneath. Place a short length of pipe (minimum 6" high) beneath the vacuum assembly to hold it in place until the spring is installed.

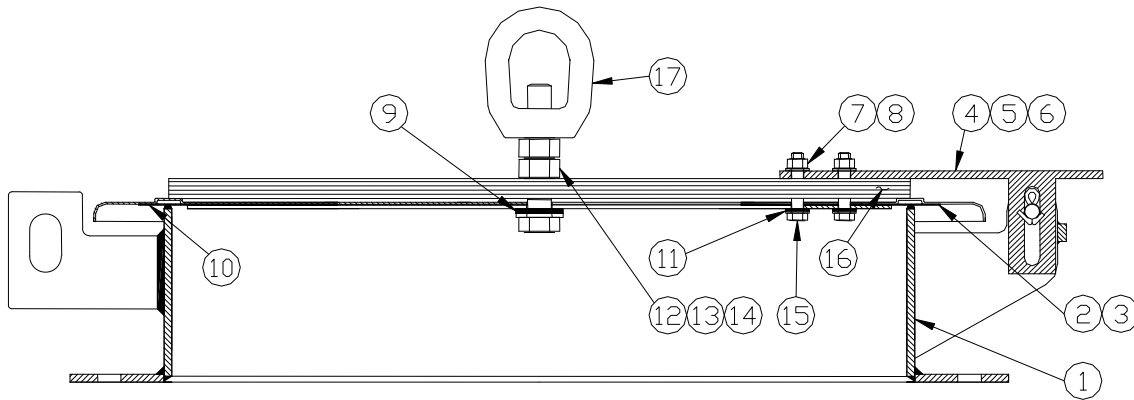
16. Place spring [31] over the stem [14]. Use the spring button [16] to compress the spring [31]. Insert nuts [15] and tighten. Compress the spring using the lower nut [15] until the “A” dimension is achieved.

**WARNING**

Failure to properly set a spring loaded valve can result in improper valve operation and can cause tank damage.

17. Install the ground cable [5]. Use a hex nut to hold in place. Add the screen [26]. *Note: Ground cable will run through the screen.*
18. Run a nut down each weatherhood post [27] approximately 0.5” to allow thread engagement when the weatherhood [13] and crown nuts [21] are installed.
19. Place weatherhood [13] on posts, and tighten with crown nuts [25].
20. Prior to final assembly, verify that the body seat area is free of corrosion, damage or product build-up. The pallet seat should be cleaned carefully, if necessary. Place pallet assembly on top of body.
21. The valve should be tested on a pressure test stand to verify the settings and evaluate seat tightness follow instructions on page 19. Mount valve on tank; see Installation on page 6.

## MODEL 2400A DISASSEMBLY & ASSEMBLY



ITEM	DESCRIPTION
1	Body
2	Pallet
3	Retainer Plate
4	Hinge Arm
5	Hinge Pin
6	Cotter Pin
7	Hex Nut, 3/8"-16 UNC
8	Lock Washer, 3/8"
9	Washer, 3/4", PTFE

ITEM	DESCRIPTION
10	Diaphragm
11	Washer, 3/8", PTFE
12	Hex Nut, 3/4"-10 UNC
13	Lock Washer, 3/4"
14	Hex Bolt, 3/4"-10 UNC
15	Hex Bolt, 3/8"-16 UNC
16	Weight Plate*
17	Eye Nut*

\* Not used on valves with low settings

### 2400A Disassembly

1. Read "Warning" sections on pages 4 and 6. Remove the valve from the tank.
2. Remove the cotter pin [6], from the hinge pin [5]. Pull the hinge pin through the body brackets. Using the eye nut [17], or the edges of the pallet, lift the cover vertically. Set the cover on a short length of pipe (minimum 6" high). This will elevate the retainer plate peripheral guides above the table so they aren't bent or damaged.
3. Place the assembly with the 3/4" hex bolt in a vise, or use a wrench to hold the center bolt from the bottom side. Loosen the hex nuts and remove. Lift the weight plate [16], pallet [2], and diaphragms [10].

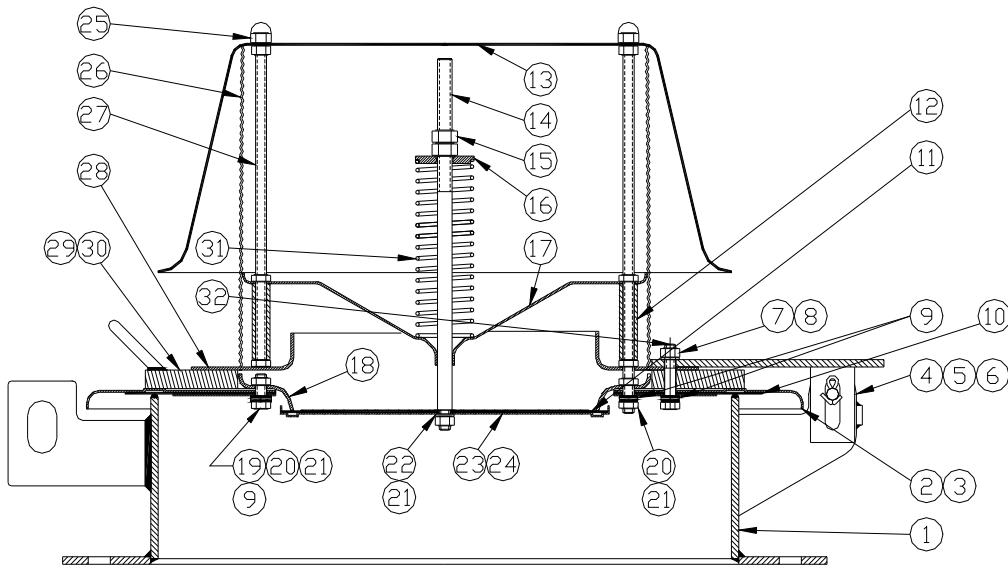
### 2400A Assembly

1. Prior to final assembly, verify that the body seat area is free of corrosion, damage or product build-up. The pallet seat should be cleaned carefully, if necessary.

**NOTE: If the seat is damaged it must be lapped using a perfectly flat ground metal disc and fine grit emery cloth attached to the disc. Wipe seating surface clean before proceeding. Soft goods should normally be replaced whenever valve maintenance is performed.**

2. Reverse the steps of Disassembly, starting with the retainer and cover. If a diaphragm is an elastomer, place it between the FEP diaphragm and the retainer plate. See Figure 3b.
3. Replace the cotter pin [6] if needed.
4. The valve should be tested on a pressure test stand to verify the settings and evaluate seat tightness follow instructions on page 19. Mount valve on tank; see Installation on page 6.

## MODEL 2450A DISASSEMBLY & ASSEMBLY



ITEM	DESCRIPTION
1	Body
2	Pallet – Pressure
3	Retainer Plate – Pressure
4	Hinge Arm
5	Hinge Pin
6	Cotter Pin
7	Hex Nut, 3/8-16 UNC
8	Lock Washer
9	Washer, 3/8", PTFE
10	Diaphragm – Pressure
11	Diaphragm – Vacuum
12	Spacer
13	Weatherhood
14	Stem – Vacuum
15	Hex Nut, 1/2-13 UNC
16	Spring Button

ITEM	DESCRIPTION
17	Stem Guide
18	Seat – Vacuum
19	Hex Bolt, 3/8-16 UNC
20	Flat Washer, 3/8", SS
21	Hex Nut, 3/8-16 UNC
22	Lock Washer, 3/8"
23	Pallet – Vacuum
24	Retainer Plate – Vacuum
25	Crown Nuts, 3/8- 16
26	Screen
27	Weatherhood Post
28	Water Dam*
29	Weight Plate*
30	Handle*
31	Spring
32	Hex Bolt, 3/8-16 UNC

\* Not used on valves with low settings.

### 2450 DISASSEMBLY

1. Read "Warning" sections on pages 4 and 6. Remove the valve from the tank.
2. Remove hinge pin [5], and cotter pin [6] from the hinge arm and brackets.
3. Lift pressure/vacuum pallet [2] with attached assembly from body [1].
4. Using the handles [30] on the weight plate [29], or the edges of the pallet [2], lift vertically. Set the cover on a short length of pipe (minimum 6" high) (Figure 13). This will elevate the retainer plate peripheral guides above the table so they aren't bent or damaged.
5. Remove crown nuts [25], lift weatherhood [13], bird screen [26] and set aside.
6. Record "A" dimension (Figure 14). Place a short length of pipe (minimum 6" high) beneath the vacuum pallet [23] to prevent it from falling. Back the top nut [15] completely off the stem. Compress the spring using the spring button [16] and grasp the stem (Figure 15). **Caution: Remove the**

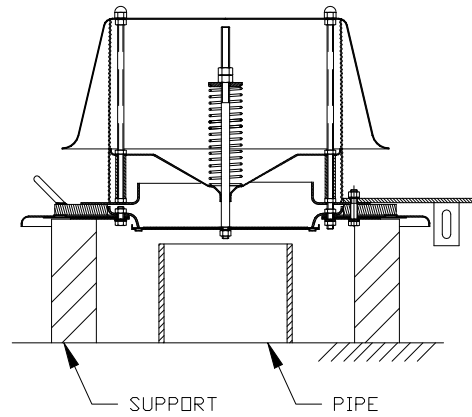
**second nut from the stem. Slowly raise the spring button to release the spring compression. The spring force will be in 5 – 30 lb range, depending on vacuum setting.**

7. Using weight plate handles, if included, lift pallet [2] with attached assembly and remove vacuum pallet-stem [23, 14] assembly from the bottom.
8. Remove the nuts on the weatherhood posts holding the stem guide [17]. Note: For low pressure settings, a weight plate is added on the stem guide [17].
9. Lift the spacers [12]. Remove the nuts above the water dam [28]. Note: Water dam is only used if weight plate is mounted directly on pressure pallet [2].
10. Remove the weatherhood posts [27] by loosening the nuts beneath the pallet.
11. Remove the hinge arm [4] by loosening the fasteners [7, 8].
12. Carefully lift the weight plate [29] vertically.  
**Caution: This may require a crane due to the weight. (See Warning on page 4.)**
13. Turn pallet assembly upside down (Figure 16).
14. Remove remaining bolts, nuts, and washers [7, 9, 19, 20, 21] to separate the vacuum seat.
15. Lift the retainer plate [3] and diaphragms [10] from the pressure pallet.

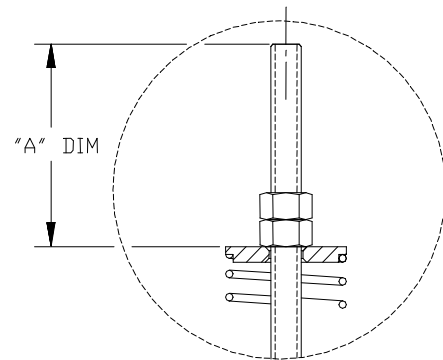
**2450 Assembly**

Rebuild the valve reversing the disassembly steps.

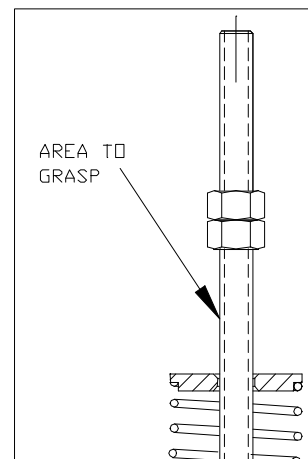
1. Begin by placing the pallet [2] upside down on support blocks evenly spaced or on a pipe.
2. Wipe clean “air cushion” groove (seat area) in pallet.
3. Center diaphragms [10] (qty 2) on pallet. See *Figure 3 for orientation of diaphragms, if elastomer is used.*



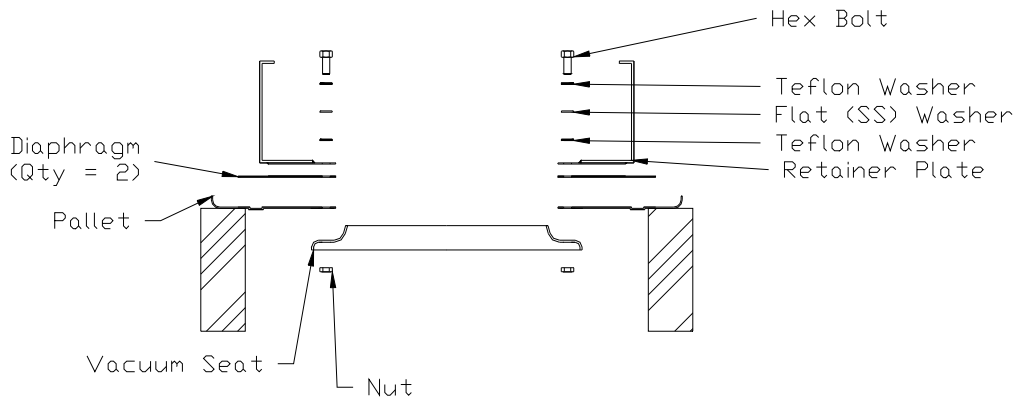
**Figure 13 : Pallet Support (2450A)**



**Figure 14 : Vacuum Spring Compression**

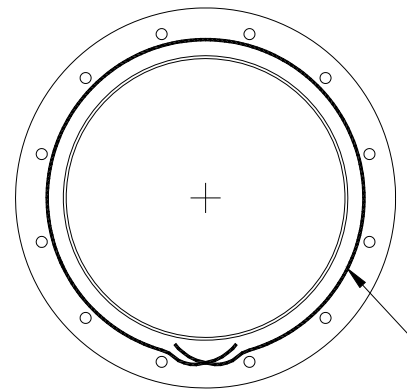


**Figure 15 : Loosening Nuts for Spring**



**Figure 16 : Exploded View of Pallet Assembly (Upside Down)**

4. Place retainer plate [3], align with pallet hole pattern.
5. Apply PTFE sealant tape around the inside hole pattern of the vacuum seat [18] (Figure 17). Tape should be at least 1/16" thick. Note: Other sealants (such as Silicone) can replace the Teflon tape if compatible with tank products.
6. Position the vacuum seat [18] as shown from beneath the pallet.
7. Align vacuum seat with pallet and insert 4 bolts (at 90 degrees from each other) from the top using fasteners shown in Figure 16 [7, 19, 20, 21].



**Figure 17 : Sealant tape on Vacuum Seat**

8. Insert four more bolts, leaving four holes, at 90 degrees from each other, open. The weatherhood posts are installed in these holes.
9. Turn pallet assembly right side up, and place on support blocks again.
10. Run 3/8" hex nut up 1 1/2" from end on all thread and insert weatherhood posts [27] in remaining holes. A Teflon washer, flat washer and nut are installed from the bottom. Allow approximately 2 threads pass the nut to be free. The four weatherhood posts should all extend approximately 11.13" above the pallet.
11. Lower the weight plate [29] (if needed for setting).
12. Set the hinge [4] above the weight plate, and insert the bolts [7, 8, 32]. Tighten.
13. Use a sealant tape around the inner edge of the weight plate. Note: Other sealants (such as Silicone) can replace the Teflon tape if compatible with tank products.
14. Insert the waterdam [28] using the weatherhood posts [27] as a guide. Use sealant tape on bottom side, outside of its hole pattern. Tighten nuts. **Note: Do not over-tighten. It is suggested to first hand tighten the nuts, torque 12 to 15 ft-lbs in an alternating criss-cross pattern.**
15. Insert the spacers, and the stem guide [17]. Tighten nut to retain to pallet assembly.

16. If pallet assembly is high enough from the table, insert vacuum pallet-stem [23, 24, 14] assembly from beneath. Place a short length of pipe (minimum 6" high) beneath the vacuum assembly to hold it in place until the spring is installed.
17. Place spring [31] over the stem [14]. Use the spring button [16] to compress the spring [31]. Insert nuts [15] and tighten. Compress the spring using the lower nut [15] until the "A" dimension is achieved.

**WARNING**

Failure to properly set a spring loaded valve can result in improper valve operation and can cause a tank failure.

18. Install the ground cable [5]. Use a hex nut to hold in place. Add the screen [26]. Note: Ground cable will run through the screen.
19. Run a nut down each weatherhood post [27] approximately 0.5" to allow thread engagement when the weatherhood [13] and crown nuts [21] are installed.
20. Place weatherhood [13] on posts, and tighten with crown nuts [25].
21. Prior to final assembly, verify that the body seat area is free of corrosion, damage or product build-up. The pallet seat should be cleaned carefully, if necessary. Place pallet assembly on top of body.
22. Slide hinge pin [5] through the body's ears and the hinge. Secure with cotter pins [6].
23. The valve should be tested on a pressure test stand to verify the settings and evaluate seat tightness follow instructions on page 19. Mount valve on tank; see Installation on page 6.

## TESTING AND SETTING PROCEDURE

### SETUP

After final assembly, mount the valve on a tank vent test stand or on a blind flange with instrument tap. Use appropriate gaskets and bolt using at least half of the available flange holes. Tighten fasteners alternately in a crossing pattern to ensure that the ERV body is not distorted or warped. If clamping is used, reduce hydraulic or pneumatic pressure to minimum.

### TESTING FOR SET PRESSURE AND SEAT LEAKAGE

Slowly increase the vessel pressure by flowing at 20 SCFH through a flowmeter. Record peak pressure attained, this pressure is the *seat leakage pressure* (as recorded on the original test report supplied by Groth Corporation at the time of order). Next increase the flow to the test tank (increasing the pressure) until an increase in flow to the test tank does not cause an increase in pressure in the tank. This pressure is the *set pressure* of the valve. At this pressure the pallet assembly will typically appear to float above seat. Conduct two additional seat leakage and set pressure tests.

### TESTING FOR SET VACUUM AND SEAT LEAKAGE

Conduct the same tests as previously described to determine the set vacuum and seat leakage.


Complete a test report indicating the actual pallet assembly weight and the peak pressure / vacuum achieved at the specified test flow rate. Maintain a copy of the test report.

### TROUBLESHOOTING

If there is excessive leakage, inspect the following:

- Inspect seat on body (Be aware of nicks, scratches and flatness.)
- Inspect diaphragm
- Inspect flatness of pallet
- Verify weight of assembly (doesn't affect vacuum operation)

In order to maintain a tight seal, components have to be clean and have a smooth surface at the contact areas.

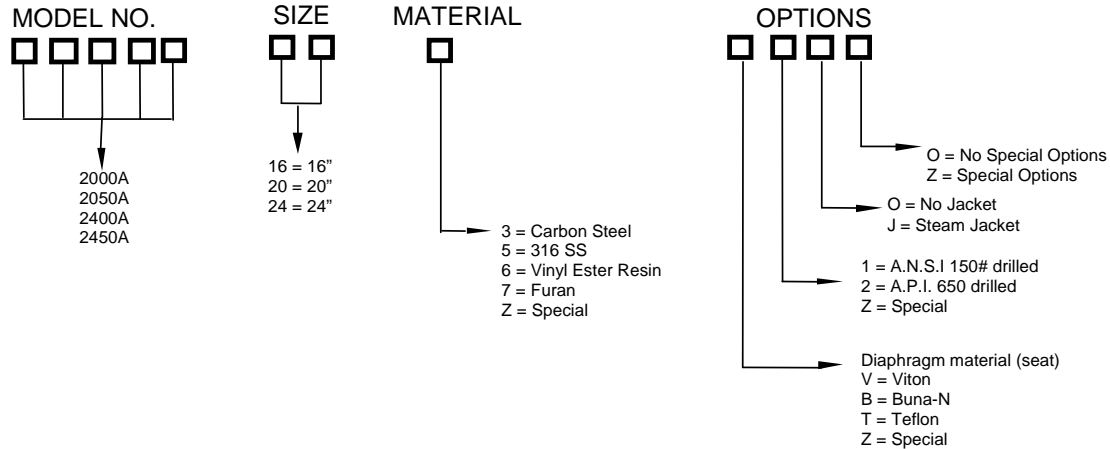
 GROTH CORPORATION STAFFORD TEXAS USA		MD:	
		S/N:	
		TAG:	
		FLANGE:	
SETTING	TYPE	% OP	FLOW [SCFH]
	PRESS.	100	
	VAC.	100	
A CONTINENTAL DISC COMPANY			

## MODEL INFORMATION

The nameplate on the Groth Series 2000A Emergency Relief Valves contains the model number, serial number, set pressure and flow capacity. The model number contains additional information about materials of construction and options. The following chart will assist in relating the model number to the specifications of your pilot operated valve:

## HOW TO ORDER

FOR EASY ORDERING, SELECT PROPER MODEL NUMBER



**Notes:** Include model number when ordering. For special options, consult factory.

### EXAMPLE

**2 0 0 0 A - 2 4 - 3 - T 1 0 0**

*Indicates a 24" 2000A Model with Carbon Steel body, Teflon diaphragm, and an ANSI 150# flange.*

## PRODUCT LIMITED WARRANTY

Only Groth's Product Limited Warranty terms apply to purchase orders accepted by Groth Corporation.

- A. Seller warrants that products that are manufactured by Seller are manufactured in accordance with published specifications and free from defects in materials and/or workmanship for a period of (12) twelve months. Seller, at its option, will repair or replace any products returned intact to the factory, transportation charges prepaid, which Seller, upon inspection, determines to be defective in material and/or workmanship. The foregoing shall constitute the sole remedy for any breach of Seller's warranty.
- B. THERE ARE NO UNDERSTANDINGS, AGREEMENTS, REPRESENTATIONS, OR WARRANTIES, EXPRESS OR IMPLIED (INCLUDING MERCHANTABILITY OR FITNESS FOR A PARTICULAR PURPOSE REGARDING PRODUCTS) UNLESS SPECIFIED IN THE SALES CONTRACT. THIS CONTRACT STATES THE ENTIRE OBLIGATION OF SELLER. Seller makes no warranties, either express or implied, except as provided herein, including without limitation thereof, warranties as to marketability, merchantability, for a particular purpose or use, or against infringement of any patent of products. In no event shall Seller be liable for any direct, incidental or consequential damages of any nature, or losses or expenses resulting from any defective new product or the use of any such product, including any damages for loss of time, inconvenience, or loss of use of any such product.
- C. The original Manufacturer shall be solely responsible for the design, development, supply, production, and performance of its products hereunder, and the protection of its trade name or names, if any. It assumes no responsibility, for products modified or changed by its agent or customer, or any other third party. Any such modifications or changes to products sold by Seller hereunder shall make the product limited warranty null and void.
- D. Groth assumes no responsibility for products modified or changed by Customer or any other third party. Any such modifications or changes to products sold by Groth hereunder shall make the product limited warranty null and void. Groth shall be under no obligation to manufacture, sell or supply, or to continue to manufacture, sell, or supply any of the products.