

Installation, Operation and Maintenance

Model 8200

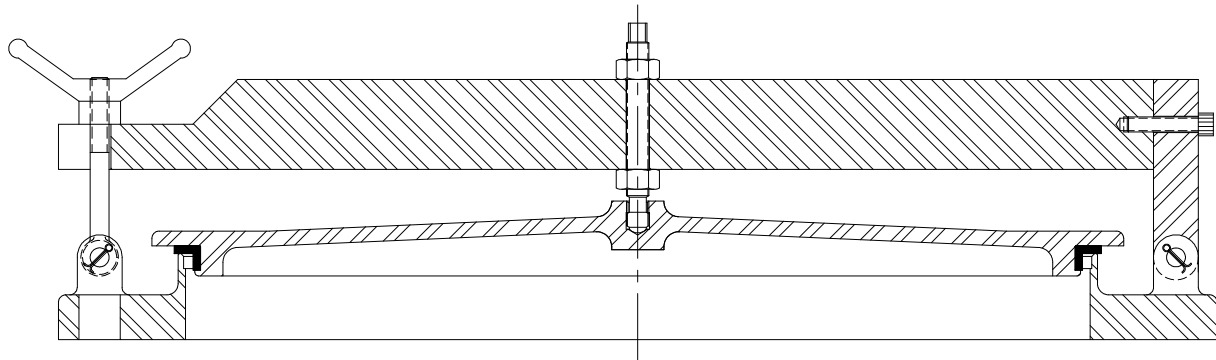

IOM 8200.2
April 2006



TABLE OF CONTENTS:

DESCRIPTION	PAGE
Introduction	2
Safety Warnings	2
Inspection and Storage	3
Installation	3
Operation	4
Maintenance	4
Factory Test and Acceptance Criteria	4
Bill of Materials & Submittal Drawings	
Model 8200	5
Abbreviations	5
Model Identification	6
Product Limited Warranty	6
LIST OF TABLES	
Table 1 - Bolt Torque (Installation)	3
Table 2 - Spare Parts P/N	4

INTRODUCTION:

This product is used when quick and easy access to a tank is desired. This product is generally placed on digester covers or roofs and is designed to be non-sparking and leak tight.

A manhole cover must be carefully maintained by a qualified technician. Carefully read and understand this manual before installing or attempting to repair a manhole cover. Groth Corporation offers repair services.

For a list of abbreviations used in this manual, refer to page 5. For information not contained in this manual, please contact:

Groth Corporation
13650 N. Promenade Blvd.
Stafford, Texas 77477, USA
(281) 295-6800 (Office)
(281) 295-6999 (Fax)

The nameplate below shows the basic information that is listed for each relief valve:

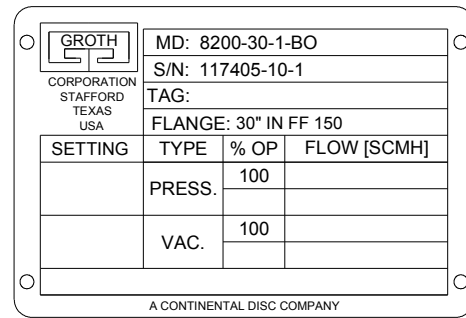

SAFETY WARNINGS:

This section is an overview of safety guidelines that should be followed during the installation, operation and maintenance of Groth Manhole Covers. To understand the context of these instructions and warnings, it is necessary to completely read and understand the contents of this manual.

The purpose of a manhole cover is to allow quick and easy access into a tank.

DO NOT attempt to open the manhole cover without first bleeding all pressure from the system.

DO NOT tamper with or modify equipment from shipped condition. All equipment is tested, as assembled, prior to shipment and any modifications will create a potential safety risk.

The manhole cover has been exposed to process vapors while in service. Observe all plant procedures and Material Safety Data Sheets (MSDS) for the products in the system when inspecting, adjusting or servicing the manhole cover. Take appropriate safety precautions regarding eye protection, respiration and skin contact.

INSPECTION AND STORAGE:

The manhole cover is carefully packaged to prevent damage or contamination during shipping. Inspect all equipment when it is received; report any damage to the carrier immediately. The manhole cover should be protected during handling and storage. Before installation, inspect the unit for indications of physical damage. If these are observed, the manhole cover must be disassembled, cleaned and repaired before installation.

INSTALLATION:

The Model 8200 is a device that must be handled carefully to ensure seat tightness.

The 8200manhole cover has a flat faced 150# ANSI flange drilling compatibility. Torque guidelines are listed in Table 1. The manhole cover is NOT rated for full flange pressure and does not require high bolting torque. Consult factory for special applications.

WARNING: *The manhole cover can be damaged by the over-tightening the studs, uneven torquing or by mounting on a tank nozzle that is not flat.*

The standard Model 8200 manhole cover is furnished with a flat flange; the manhole cover should be mounted on a flat faced 150# ANSI flange. It is recommended to use a full faced gasket to avoid deflecting the flange. The connecting flanges must be flat within 0.015" and clean, free of scratches, corrosion and tool marks.

1. Begin by inspecting the gasket; make sure that the material is suitable for service.
2. Lubricate all studs and nuts with an appropriate thread lubricant. If stainless steel fasteners are used, select an anti-seize lubricant such as moly-disulfide.
3. Align the gasket with the bolt circle.
4. Set the manhole cover carefully on the nozzle; keep the gasket between the flanges. Install the studs and tighten nuts hand tight.
5. Torque all fasteners to half the recommended value (see Table 1) in a staggered, alternating pattern or follow appropriate Plant Maintenance guidelines and standards.

	Size	Qty Holes	Bolt (in) (UNC)	Torque (ft-lbs)
150 #ANSI	20"	20	1.125	75
	24"	20	1.250	75
	30"	28	1.250	75
	36"	32	1.500	75

*Note: Torque values are based on a gasket factor $m=3.5$, gasket factor $y=2000$ psi, maximum pressure = 2 psi.

6. Make sure that the flanges are not distorted and that the gasket is evenly compressed.
7. Make up the final torque and check that no further nut rotation occurs.

OPERATION:

1. For inspection or entry into the tank, release and disengage the handle and lift the manhole cover to full open position. The weight of the cover will keep it open.

WARNING: *DO NOT attempt to open the manhole cover without first venting toxic or flammable fumes or liquids from tank to a safe location to prevent personal injury or property damage.*

2. To close the cover, lower slowly into seat, engage handle and tighten until a leak tight seal is achieved (this occurs when the handle threads bottom out on the eye bolt threads).

WARNING: *If the handle is over tightened damage to the manhole cover can occur. DO NOT tamper with or modify equipment from shipped condition. All equipment is tested, as assembled, prior to shipment and any modifications will create a potential safety risk.*

MAINTENANCE:

Groth Corporation recommends that all service performed on a manhole cover be done at the factory.

Refer to Fig. 1 on the next page, which illustrates a typical manhole cover when disassembling the unit.

WARNING: *Before disassembling the manhole cover carefully read and understand the Safety Warnings listed on page 2.*

1. Check the metal seating surfaces for pitting, corrosion or product build up. It is recommended to replace the seal ring (#1). For a list of recommended spare parts see Table 2.

NOTE: Wipe the seating surface clean before proceeding.

2. Make sure that the manhole cover sits flat on the seat when the handle is tightened. The handle should be tightened until a leak tight seal is achieved.

WARNING: *When assembling a manhole cover do not adjust the center stud (#7). When assembling the manhole arm do not add hardware between the handle (#5) and the arm (#9). Adjustment may cause physical damage to components or prevent sealing.*

TABLE 2: Part Numbers - Spare Parts *

Component	Valve Size			
	20"	24"	30"	36"
Seal Ring (Buna N)	1013820B	1013824B	1013830B	1013836B

*Please provide the manhole cover serial number when ordering replacement parts.

FACTORY TEST AND ACCEPTANCE CRITERIA:

1. Pressurize the manhole cover to 1 psig.
2. Test the seat for leaks.

ACCEPTANCE CRITERIA:

3. No visible leaks are acceptable.
4. Complete a Test Report indicating the peak pressure achieved while maintaining a leak tight seal.
5. A copy of the Test Report shall be maintained with the Valve Maintenance Records.

Groth Model 8200 Manhole Cover

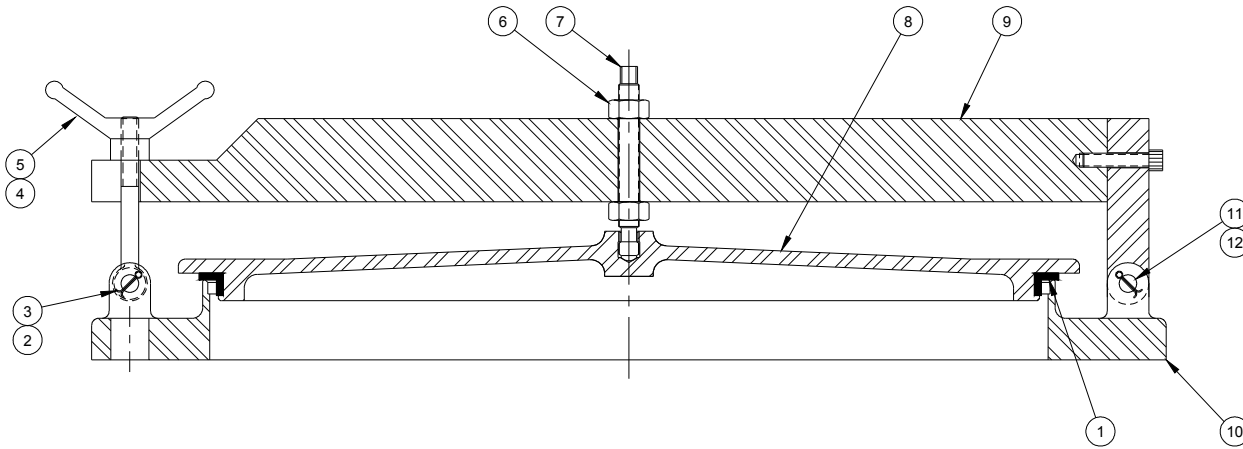

Fig. 1

ITEM	DESCRIPTION	ALUMINUM
1	Seal Ring*	Buna-N
2	Cotter Pin	SS
3	Front Hinge Pin	304 SS
4	Eye Bolt	CS
5	Handle	CS
6	Hex Nut	CS
7	Stud	316 SS
8	Cover	Aluminum
9	Arm	Aluminum
10	Body	Aluminum
11	Hinge Pin	304 SS
12	Cotter Pin	SS

* = Recommended Spare Parts

LIST OF ABBREVIATIONS

ANSI	American National Standard
API	American Petroleum Institute
cm	Centimeter
ERV	Emergency Relief Valve
In.	Inches
In. WC	Inches Of Water Column
kg	Kilogram
kg.m	Kilogram-meter
Lb.	Pound
Lb.in.	Pound Inch

MAWP	Max Allowable Working Press.
Max.	Maximum
MD	Model
mil	Thousands Of An Inch
Min.	Minimum
mm	Millimeter
MSDS	Material Safety Data Sheet
OP	Over Pressure
OSI	Ounces Per Square Inch
OZ	Ounces

P	Pressure
P/N	Part Number
POV	Pilot Operated Valve
PSIG	Pounds Per Square Inch
S/N	Serial Number
SCFH	Standard Cubic Ft Per Hour
SLV	Spring Loaded Valve
TVTS	Tank Vent Test Stand
V	Vacuum
WLV	Weight Loaded Valve

The nameplate on the manhole cover contains the Model Number and Serial Number. The Model Number contains additional information about materials of construction, soft goods and options. The following chart will assist in relating the Model Number to the characteristics of your valve:

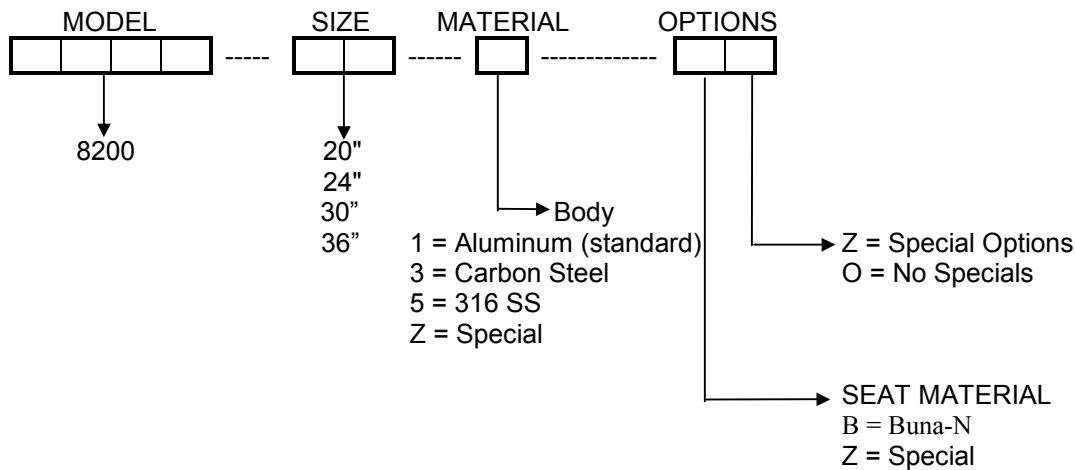

Teflon® is a registered trademark of E.I. du Pont de Nemours and Co. used under license.

EXAMPLE: 8200-30-1-BO indicates a 30" Model 8200 with Aluminum construction, Buna-N seal ring and no special options.

PRODUCT LIMITED WARRANTY

- A. Seller warrants that products which are manufactured by Seller, are manufactured in accordance with published specifications and free from defects in materials and/or workmanship for a period of (12) twelve months. Seller, at its option, will repair or replace any products returned intact to the factory, transportation charges prepaid, which Seller, upon inspection, shall determine to be defective in material and/or workmanship. The foregoing shall constitute the sole remedy for any breach of Seller's warranty.
- B. THERE ARE NO UNDERSTANDINGS, AGREEMENTS, REPRESENTATIONS, OR WARRANTIES, EXPRESS OR IMPLIED, (INCLUDING MERCHANTABILITY OR FITNESS FOR A PARTICULAR PURPOSE REGARDING PRODUCTS) UNLESS SPECIFIED IN THE SALES CONTRACT . THIS CONTRACT STATES THE ENTIRE OBLIGATION OF SELLER.

Seller makes no warranties, either express or implied, except as provided herein, including without limitation thereof, warranties as to marketability, merchantability, for a particular purpose or use, or against infringement of any patent of products. In no event shall Seller be liable for any direct, incidental or consequential damages of any nature, or losses or expenses resulting from any defective new product or the use of any such product, including any damages for loss of time, inconvenience, or loss of use of any such product.
- C. The original Manufacturer shall be solely responsible for the design, development, supply, production, and performance of its products hereunder, and the protection of its trade name or names, if any. It assumes no responsibility, for products modified or changed in any way by its agent or customer. Any such modifications or changes to products sold by Seller hereunder shall make the product limited warranty null and void.
- D. The Manufacturer shall be under no obligation to manufacture, sell, or supply, or to continue to manufacture, sell or supply any of the Products.