

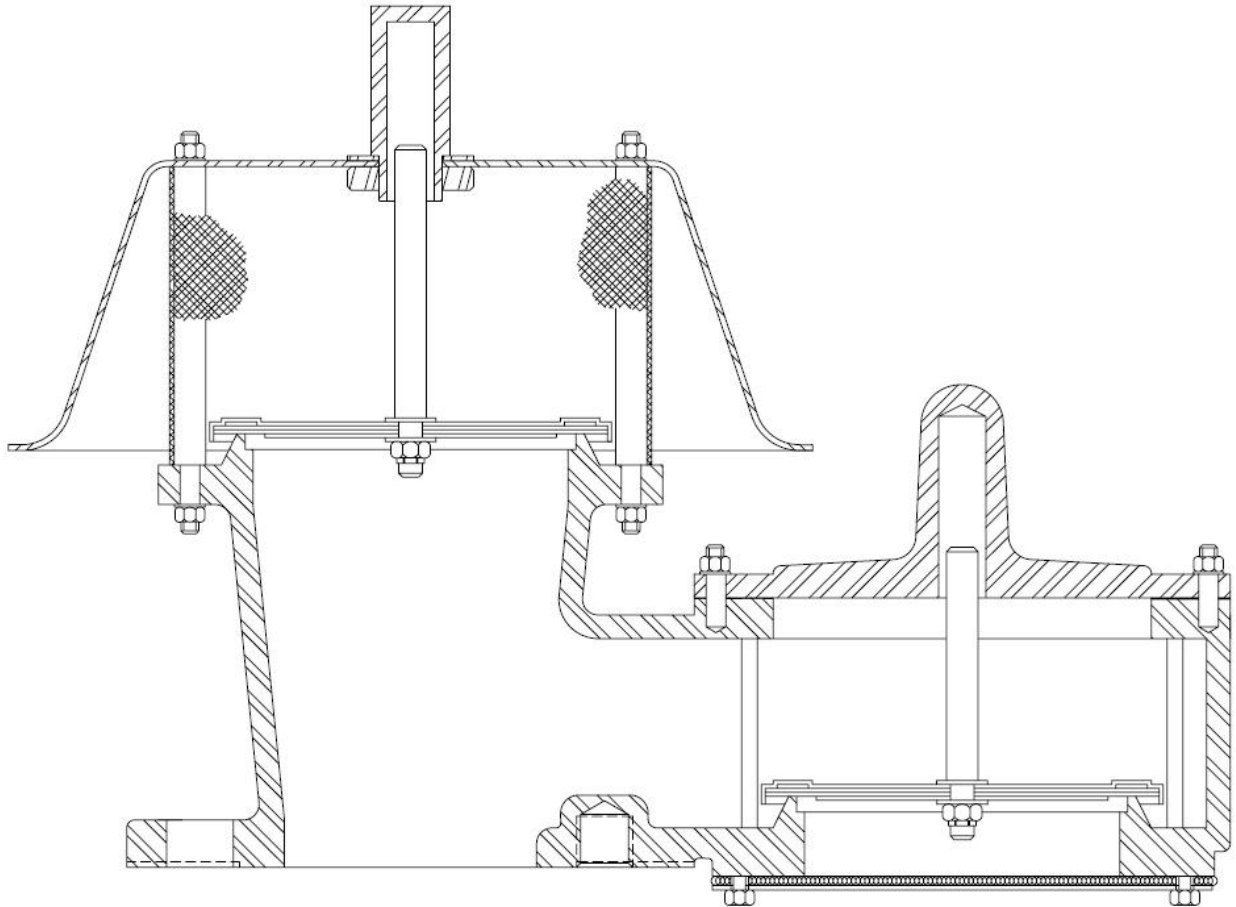

Installation, Operation and Maintenance Manual for Pressure/Vacuum Relief Valves

Models 1800A, 1810A, 1820A, 1830A, 1860A, 1870A



IOM-1800A
Rev. IR
Ref. ID: 95806

TABLE OF CONTENTS

I.	INTRODUCTION	3
II.	DESIGN AND FUNCTION	4
	1. FIGURE 1 – TYPICAL TANK INSTALLATION	4
	2. FIGURE 2 – PRESSURE RELIEF	4
	3. FIGURE 3 – VACUUM RELIEF	4
III.	SAFETY WARNINGS	5
IV.	INSPECTION AND STORAGE	5
V.	INSTALLATION	6
	1. TABLE 1 – BOLT TORQUE AND STUD SPECIFICATIONS	6
	2. TABLE 2 – VALVE WEIGHTS AT MAXIMUM SETTINGS	6
VI.	MAINTENANCE	7
	1. FIGURE 4 – VALVE CROSS SECTION	7
	2. FIGURE 5 – PALLET DETAIL	7
	3. TABLE 3 – STEM LENGTH	8
	4. FIGURE 6 – SEAT INSERT DETAIL	8
VII.	VALVE TESTING PROCEDURE	9
	1. TABLE 4 – SEAT LEAKAGE TEST CRITERIA	9
VIII.	MODEL IDENTIFICATION	10
IX.	PRODUCT LIMITED WARRANTY	11
X.	APPENDIX A – MODEL 1800A PRESSURE/VACUUM RELIEF VALVE	12
XI.	APPENDIX B – MODEL 1810A VACUUM RELIEF VALVE	13
XII.	APPENDIX C – MODEL 1820A PRESSURE/VACUUM RELIEF VALVE	14
XIII.	APPENDIX D – MODEL 1830A PRESSURE RELIEF VALVE	15
XIV.	APPENDIX E – MODEL 1860A PRESSURE RELIEF VALVE	16
XV.	APPENDIX F – MODEL 1870A VACUUM RELIEF VALVE	17

I. INTRODUCTION

Pressure and/or vacuum relief valves are used on liquid storage tanks and other process vessels or systems to prevent structural damage due to excess internal pressure or vacuum.

Storage tanks are pressurized when liquid is pumped in, compressing the existing vapor or when rising temperatures cause increased evaporation or expansion of existing vapor. Conversely, a vacuum condition may be created when pumping out or due to falling temperature. To prevent tank damage, vapor must be allowed into or out of the tank at specified pressure/vacuum conditions. The volume rate of venting depends upon the tank size, volatility of the tank contents, the pumping rates and the temperature. Refer to API Standard 2000, ISO 28300, or local regulations for the procedures to determine venting requirements.

A relief valve must be carefully maintained by a qualified valve technician. It should only be assembled under clean conditions, preferably in a service shop environment. Carefully read and understand this manual before installing or attempting to repair a valve.

For information not contained in this manual, please contact:

Groth Corporation
13650 N. Promenade Blvd.
Stafford, TX, 77477 USA
Phone: 281-295-6800
Fax: 281-295-6999
www.grothcorp.com

II. DESIGN AND FUNCTION

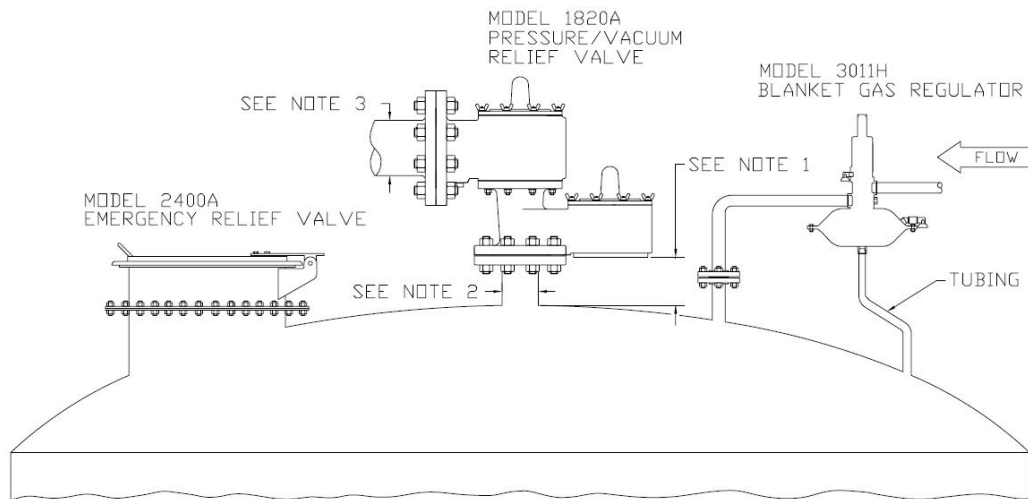

Figure 1 - Typical Tank Installation

Tank protection equipment typically includes an operating valve which is designed to provide pressure/vacuum relief under normal pump in/out and thermal breathing conditions. An emergency relief valve can also provide both pressure and vacuum relief and normally it is sized to provide pressure relief if there is a fire in the immediate vicinity of the tank. It may also be sized by the tank designer to provide protection in the event of equipment failure (such as the rupture of a process steam line or an inert gas blanketing system failing open) or operator error.

A typical tank installation is shown in Figure 1 which includes the following Groth products:

1. Model 1820A Pressure/Vacuum Weight Loaded Valve
2. Model 3011H Gas Blanketing Regulator
3. Model 2400A Emergency Pressure Relief Valve

Pressure Relief: As the pressure in the storage tank increases, the vacuum pallet is held shut.

When the set pressure is reached, the pressure pallet lifts and relieves tank pressure to the atmosphere (or to a header if it is a pipe away valve). See Figure 2.

Vacuum Relief: As a vacuum is drawn in the storage tank (for example, when fluid is being pumped out), the pressure pallet is held shut. When the vacuum setting is reached, the vacuum pallet lifts and air is drawn into the tank from the atmosphere. See Figure 3.

Figure 2 – Pressure Relief

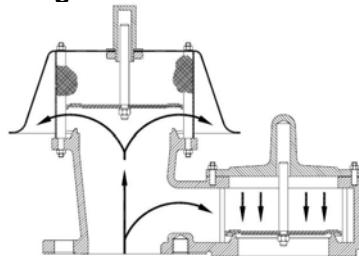
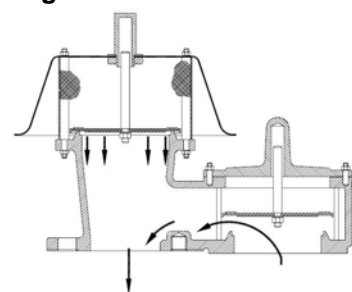

Figure 3 – Vacuum Relief



INSTALLATION NOTES: (See Figure 1)

1. Minimum clearance between tank roof and vacuum inlet port must be at least equal to the valve nominal flange bore.
2. Tank nozzle bore must be greater than or equal to the valve inlet flange bore.
3. Inlet and outlet piping loads must be supported by appropriate structural supports, NOT by the valve body.

III. SAFETY WARNINGS

This section is an overview of safety guidelines that should be followed during the installation, operation and maintenance of Groth Pressure/Vacuum Relief Valves. To understand the context of these instructions and warnings, it is necessary to completely read and understand the contents of this manual.

The purpose of a weight loaded pressure/vacuum relief valve is to prevent excessive pressure or vacuum in a tank or process system. The valve must be designed for the proper Maximum Allowable Working Pressure (MAWP) and flow requirements of the system. Consult API Standard 2000, ISO 28300, or local regulations for tank protection sizing procedures. An improperly specified or functioning relief valve may result in structural damage to the tank or system, and can cause severe personal injury or death.

Valves are set at the factory according to purchase order specifications. Do NOT change pressure ratings by adding additional weights to the pallet assembly without consulting the factory or your local Groth representative. Adding weights to a valve may restrict pallet lift and reduce the valve's rated flow capacity.

DO NOT mix pressure/vacuum pallet assemblies. Failure to ensure that both pallet assemblies are installed in the correct location can change the pressure and vacuum relief settings or restrict lift of the pallet. This can cause a tank failure.

DO NOT attempt to remove the valve from the tank or process vessel without first bleeding all pressure from the system. ALTERNATIVE MEANS OF PRESSURE RELIEF MUST BE PROVIDED WHEN THE VALVE IS OUT OF SERVICE.

If the valve has been exposed to process vapors while in service, observe all plant procedures and Material Safety Data Sheets (MSDS) for the products in the system when inspecting, adjusting or servicing the valve. Take appropriate safety precautions regarding eye protection, respiration and skin contact.

The tank pressure required to discharge the normal or emergency venting requirements of the tank will be increased by the amount of back pressure in the discharge header, on a pipe away valve configuration. Maximum possible discharge header pressure must be considered when sizing the pressure relief valve.

IV. INSPECTION AND STORAGE

The pressure/vacuum relief valve is carefully packaged to prevent damage or contamination during shipping. Inspect all equipment when it is received; report any damage to the carrier immediately. The valve should be protected during handling and storage. Keep all the ports plugged to prevent intrusion of foreign materials. Before installation, inspect the unit for indications of physical damage or internal contamination. If these are observed, the valve must be disassembled, cleaned and repaired before installation.

V. INSTALLATION

A typical valve installation on a tank or vessel is illustrated in Figure 1, Page 4 using a Model 1820A Pressure/Vacuum Relief Valve. Groth's weight loaded Pressure/Vacuum Relief Valves are designed to provide tank protection for both pressure and/or vacuum to +/-0.5 PSIG settings. The valves provide full rated flow capacity at 10% over-pressure. Consult factory for performance under other conditions.

WARNING: The valve must be installed in a vertical position as shown in Figure 1, Page 4. To achieve nominal flow capacity, the tank nozzle bore must be at least the same nominal dimension as the relief valve inlet body.

This series of valves all have 150# ANSI flange drilling, unless otherwise specified. Torque guidelines are listed in Table 1, Page 6. Consult factory for special applications.

The following guidelines should be observed at installation:

1. Inspect the gasket seating surface of the tank nozzle flange. It must be clean, free of scratches, corrosion, tool marks, and flat.
2. Aluminum valves are furnished as a standard with flat face flanges; they should only be installed on a mating flat face flange with a full faced gasket.
3. Inspect the gasket; make sure that the material is suitable for the application.
4. Lubricate all studs and nuts with an appropriate thread lubricant. If the valve will see high temperature service or stainless steel fasteners are used, apply an anti-seize compound such as moly-disulfide.
5. Center the gasket within the bolt circle.
6. Set the valve carefully on the nozzle. Install the studs and tighten nuts hand tight. For studs selection for blind tapped holes see Table 1, Page 6.
7. Torque all fasteners to half the value listed in Table 1, Page 6, in a staggered, alternating pattern.
8. Make sure that the flanges are not distorted and that the gasket is evenly compressed. Make up the final torque and check that no further nut rotation occurs at the torque value specified on Table 1, Page 6.

Table 1 - Bolt Torque & Stud Specifications - ANSI #150 Flange Connections

Mounting Flange	Bolt Torque – Lb-Ft(N-m)		Number Bolts Total	Stud Specifications		
	Raised Face	Flat Face		Thread UNC	Stud Length *	Qty *
2"	30 (41)	60 (81)	4	5/8" - 11	2.25"	2
3"	54 (73)	108 (146)	4	5/8" - 11	2.50"	2
4"	42 (57)	78 (106)	8	5/8" - 11	2.50"	4
6"	90 (122)	150 (203)	8	3/4" - 10	3.00"	4
8"	126 (171)	228 (309)	8	3/4" - 10	3.00"	4
10"	138 (187)	246 (334)	12	7/8" - 9	3.50"	6
12"	186 (252)	348 (472)	12	7/8" - 9	3.50"	6

(*) - Blind tapped holes only (1800A, 1810A, & 1820A). Use standard ANSI stud length for other holes.

Table 2 - Valve Weights @ Minimum Settings (Aluminum) - Lb. (kg)

Valve Size	1800A	1810A	1820A	1830A	1860A	1870A
2"	16 (7)	15 (7)	26 (12)	12 (5)	16 (7)	12 (6)
3"	21 (9)	21 (10)	34 (16)	15 (7)	22 (10)	17 (8)
4"	31 (14)	32 (14)	49 (22)	20 (9)	29 (13)	23 (10)
6"	57 (26)	61 (28)	93 (42)	30 (14)	55 (25)	42 (19)
8"	75 (34)	81 (37)	137 (62)	45 (20)	92 (42)	71 (32)
10"	116 (53)	121 (55)	186 (85)	65 (30)	105 (48)	83 (38)
12"	157 (71)	165 (75)	260 (118)	100 (45)	149 (68)	118 (54)

VI. MAINTENANCE

Groth Corporation recommends that all service performed on a pressure/vacuum relief valve is done at a Groth Authorized Repair Dealer. Contact Groth Corporation for your local authorized repair dealer. Trained mechanics with specialized test equipment will ensure that the valve is accurately set.

It is important to regularly inspect the diaphragm, guides and seating surfaces to ensure the valve can open freely. Refer to Figure 4 which illustrates a typical Pressure/Vacuum relief valve when disassembling the unit.

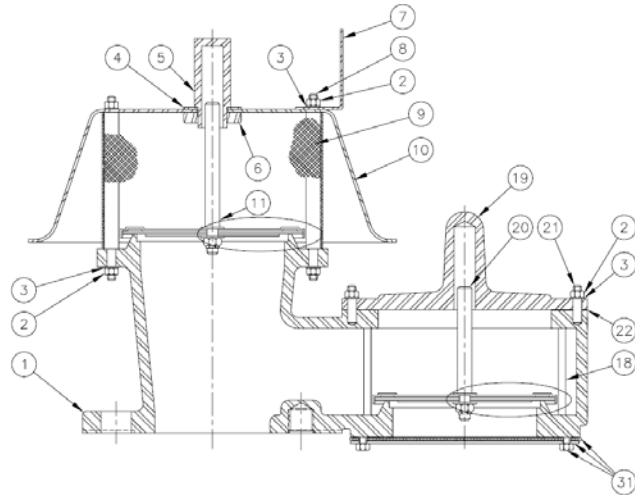

Figure 4 – Valve Cross Section

WARNING: Before disassembling valve carefully read and understand the Safety Warnings listed on page 5.

Refer to the Figure 4 and 5 for Part References

1. Loosen and remove all nuts (#2) and washers (#3).
2. Lift off the vacuum cover (#19) and weatherhood (#10). The weatherhood and weatherhood posts (#8) have a snug fit. Loosen the hex nuts (#2) and washers (#3) that retain the weatherhood posts in the body a few turns; this will allow the weatherhood to be removed easily.
3. Remove the vacuum and pressure pallet assemblies by firmly grasping the stems (#11 & #20) and lifting up. Depending on the pressure/vacuum settings of the particular valve, weight plates may have been added to the pallet assemblies. The weights and pallets must be reinstalled in their original locations. Make sure that all weight plates stay with the appropriate pallet assembly. Tag the assemblies "Pressure" and "Vacuum" as they are removed from the valve. Take proper precaution as lead weights may have been used.
4. Carefully inspect all guides (#18) for corrosion, damage or product build up. Also inspect the guide hole in the vacuum cover (#19). Check the metal seating surfaces for pitting, corrosion or product build up. It is recommended to replace all soft goods including diaphragms (#13, #14, #24 & #25), O-Ring (#27) and cover gasket (#22).



Figure 5 – Pallet Detail

NOTE: If the metal seating surfaces are damaged, they must be lapped using a flat ground metal disc, flatness better than 0.005", and fine grit emery cloth attached to the disc. Wipe the seating surface clean before proceeding.

5. If the stems are being replaced, check Table 3 to ensure that the correct length is being used in both the pressure and vacuum ports.
6. Verify that the pallets and weights are back in their proper location. Assemble in reverse order. Make sure that pallet assemblies sit flat on the seat and that the stem is not cocked when the weatherhood (#10) and vacuum cover (#19) are installed. Tighten all nuts firmly.

WARNING: When assembling a P/V valve, always use the correct length stem (as specified in Table 3), put the pressure and vacuum pallet assemblies back in their original location and ensure that the stem is straight and fits into the guide in the cover or weatherhood.

1. If the stem length is too long, pallet lift will be restricted; the valve will not attain its full rated flow capacity.
2. If the pressure and vacuum pallet assemblies are mixed at assembly, the settings will be changed and pallet lift may be completely blocked. An over-pressure can occur if any of these three conditions happens. This can cause a tank failure, severe personal injury and material damage.

Valve Size (In)	Table 3 - Stem Length			
	Pressure Port		Vacuum Port	
	Pipe-Away in (cm)	Weatherhood in (cm)	Side Mount in (cm)	All Others in (cm)
2	5.25 (13.34)	7.44 (18.90)	N/A	4.69 (11.91)
3	6.88 (17.46)	7.44 (18.90)	5.25 (13.34)	5.81 (14.77)
4	8.94 (22.70)	8.94 (22.71)	6.88 (17.46)	7.13 (18.10)
6	11.94 (30.32)	11.75 (29.85)	8.94 (22.70)	8.88 (22.54)
8	13.56 (34.45)	11.94 (30.33)	11.94 (30.32)	10.88 (27.62)
10	14.94 (37.94)	10.88 (27.64)	13.56 (34.45)	12.63 (32.07)
12	16.56 (42.07)	11.75 (29.85)	14.94 (37.94)	14.94 (37.94)
14	N/A	N/A	16.56 (42.07)	N/A

Seat Replacement (6" – 12" only)

1. The insert is retained in the casting by [3] stainless steel socket head set screws threaded radially through the insert. See Figure 6.
2. Remove the screws [#29] with a hex wrench. The screws were installed with Lok-Tite thread sealant, so you may need some heat to break them loose.
3. Remove the insert [#27] from the casting by applying force uniformly around the perimeter. The O-Ring [#28] will resist removal, but there is a groove between the insert and casting where force can be applied.
4. Replace or re-install the seat insert with a new O-Ring [#28]. Lightly coat the O-Ring [#28] with grease and install into the groove in the insert [#28].
5. Install insert [#27] in the casting and press in all around until insert is in firm metal-to-metal contact with the casting.
6. Apply 3-4 drops of Lok-Tite thread sealant to each of the [3] set screws and insert them into the insert until they contact the casting hand-tight.

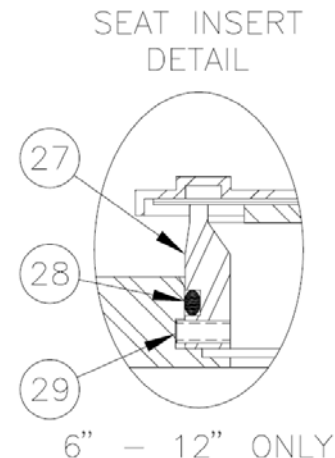

Figure 6 – Seat Insert Detail

VII. VALVE TESTING PROCEDURE

General Information

1. Use only appropriate testing equipment designated by local regulations (e.g. API 2000, ISO 28300, EN14015).
2. Calibrate all measuring devices according to device manufacturer schedule.

Seat Leakage Test (Pressure/Vacuum)

1. Test the pressure and/or vacuum seat leakage three times to verify leak tightness. Record all test pressure and vacuum readings on the *Shop Data Sheet*.
2. Slowly open the Test Stand Pressure Test or Vacuum Test valve (supply pressure).
3. Adjust the appropriate flow meter to achieve the specified flow rate listed **Table 4** below.
4. With the valve flowing at the flow rate indicated in **Table 4**, read the test stand supply pressure using the manometer or gauge.
5. The acceptance criteria for this test are that the peak pressure attained at the specified flow rate be **at least 75%** of the specified set pressure or vacuum listed on the sales order.
Perform this test three times to verify proper operation.
6. If the valve fails to meet the 75% criteria, it must be disassembled and the pallet, diaphragm or seat repaired or replaced. The pallet assembly shall be weighed to confirm that it meets the weight tolerance specified in the appropriate Assembly Procedure. If the pallet assembly weight exceeds the limits, adjust the pallet weights and retest beginning at Section 4.3.2.
7. Record the test results under the *Seat Leakage Test 1-3 (Pressure/Vacuum)* on a *Shop Data Sheet*.

Table 4: Seat Leakage Test Criteria

Valve Size	Test Flow Rate
2" - 6"	0.5 ft ³ /hr (0.0142 m ³ /hr)
8"- 12"	5.0 ft ³ /hr (0.1416 m ³ /hr)

Set Pressure and/or Vacuum Test

1. Test the set pressure and/or vacuum three times to verify proper operation. Record all test pressure and vacuum readings on the *Shop Data Sheet*.
2. With the valve mounted on the test stand from previous test, slowly increase the pressure while monitoring the air supply pressure flow rate. For vacuum tests, the block valve is opened sufficiently to allow a steady increase in vacuum condition. As the setting is approached, continue to open the valve.
3. The set pressure (vacuum) will be the point at which the test pressure (vacuum) does not increase with a corresponding increase in flow rate. Normally, at this point, the test pressure (vacuum) will fluctuate up and down as the valve relieves, while the flow rate remains steady. The set pressure or set vacuum is the maximum pressure or vacuum achieved during the test.
4. Repeat this test two more times to achieve a total of three measurements of set pressure and vacuum.
5. The acceptable tolerance range for set pressure (vacuum) is +/- 10%. All three test results must fall within the specified tolerances for the pressure and vacuum settings listed on the sales order. Record the three set pressures and vacuum measurements on the *Shop Data Sheet*.
6. If all three set test values are not within the allowable tolerance, disassemble the valve; inspect the pallet, seat and diaphragms. It may be necessary to lap the seat or replace one or more components. If the pallet weight falls within the limits, but still exceeds either the pressure or vacuum setting tolerance, consult Groth Corporation.

VIII. MODEL NUMBER IDENTIFICATION

The nameplate on the Valve contains the Model Number, Serial Number, set pressures and flow capacity at a specified over-pressure. The Model Number contains additional information about materials of construction, soft goods and options. The following chart will assist in relating the Model Number to the characteristics of your valve:

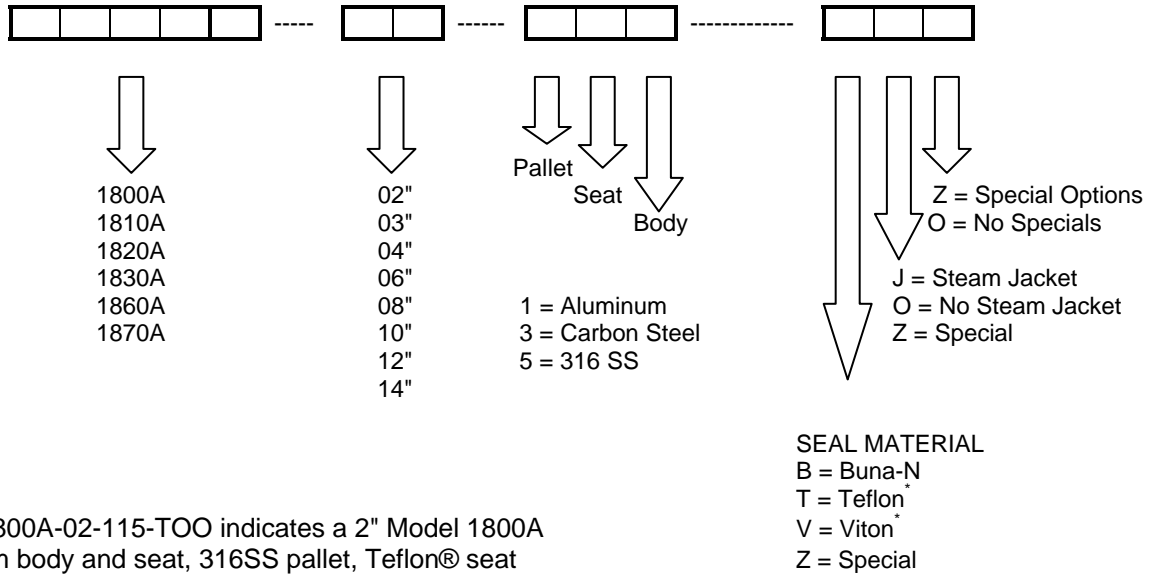

EXAMPLE: 1800A-02-115-TOO indicates a 2" Model 1800A with Aluminum body and seat, 316SS pallet, Teflon® seat diaphragms and no special options.

*Teflon is a registered trademark of Dupont used under license by Continental Disc Corporation

The nameplate below shows the basic information that is listed for each relief valve:

 CORPORATION STAFFORD, TX, USA		MD:	
		S/N:	
		TAG:	
FLANGE:			
SETTING	TYPE	% OF FLOW	[SCFH]
	PRESS.	100	
	VAC.	100	
A CONTINENTAL DISC COMPANY			

II. PRODUCT LIMITED WARRANTY

Only Groth's Product Limited Warranty terms apply to purchase orders accepted by Groth Corporation.

Seller warrants that products that are manufactured by Seller are manufactured in accordance with published specifications and free from defects in materials and/or workmanship for a period of (12) twelve months. Seller, at its option, will repair or replace any products returned intact to the factory, transportation charges prepaid, which Seller, upon inspection, determines to be defective in material and/or workmanship. The foregoing shall constitute the sole remedy for any breach of Seller's warranty.

THERE ARE NO UNDERSTANDINGS, AGREEMENTS, REPRESENTATIONS, OR WARRANTIES, EXPRESS OR IMPLIED (INCLUDING MERCHANTABILITY OR FITNESS FOR A PARTICULAR PURPOSE REGARDING PRODUCTS) UNLESS SPECIFIED IN THE SALES CONTRACT. THIS CONTRACT STATES THE ENTIRE OBLIGATION OF SELLER.

Seller makes no warranties, either express or implied, except as provided herein, including without limitation thereof, warranties as to marketability, merchantability, for a particular purpose or use, or against infringement of any patent of products. In no event shall Seller be liable for any direct, incidental or consequential damages of any nature, or losses or expenses resulting from any defective new product or the use of any such product, including any damages for loss of time, inconvenience, or loss of use of any such product.

The original Manufacturer shall be solely responsible for the design, development, supply, production, and performance of its products hereunder, and the protection of its trade name or names, if any. It assumes no responsibility, for products modified or changed by its agent or customer, or any other third party. Any such modifications or changes to products sold by Seller hereunder shall make the product limited warranty null and void.

Groth assumes no responsibility for products modified or changed by Customer or any other third party. Any such modifications or changes to products sold by Groth hereunder shall make the product limited warranty null and void. Groth shall be under no obligation to manufacture, sell or supply, or to continue to manufacture, sell, or supply any of the products.

APPENDIX A: Model 1800A Pressure/Vacuum Relief Valve

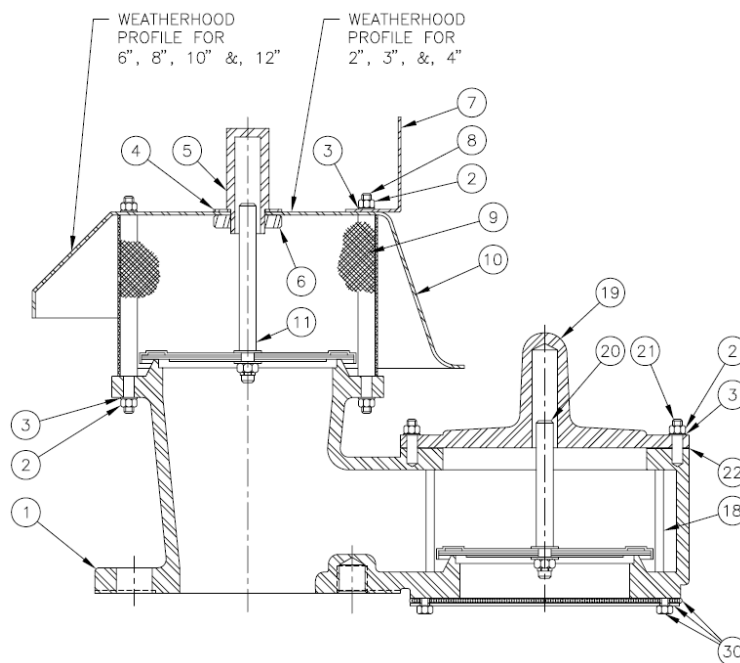

ITEM	DESCRIPTION	STANDARD MATERIALS OF CONSTRUCTION		
		ALUMINUM	CARBON STL	316 SS
1	BODY	AL(GR 356-T6)	CS(GR WCB)	316 SS(GR CF-8M)
2	HEX NUT	SS	SS	SS
3	LOCK WASHER	SS	SS	SS
4	FLAT WASHER	SS	SS	SS
5	STEM GUIDE	ALUM	CS	316 SS
6	HEX JAM NUT	SS	SS	SS
7	LIFTING LUG (3"-12" ONLY)	GALV CS	GALV CS	GALV CS
8	WEATHERHOOD POST	316 SS	316 SS	316 SS
9	PRESSURE SCREEN	316 SS	316 SS	316 SS
10	WEATHERHOOD	ALUM	CS	316 SS
11	PRESSURE STEM	316 SS	316 SS	316 SS
12	PRESSURE PALLET (1) (NOT SHOWN)	316 SS	316 SS	316 SS
13	* PRESSURE DIAPHRAGM, PRIMARY (2)(3) (NOT SHOWN)	FEP Teflon®	FEP Teflon®	FEP Teflon®
14	* PRESSURE, DIAPHRAGM, BACKUP (2) (NOT SHOWN)	FEP Teflon®	FEP Teflon®	FEP Teflon®
15	RETAINER PLATE (NOT SHOWN)	316 SS	316 SS	316 SS
16	FLAT WASHER (NOT SHOWN)	SS	SS	SS
17	HEX EXPANDING LOCK NUT (NOT SHOWN)	SS	SS	SS
18	GUIDE ROD	316 SS	316 SS	316 SS
19	COVER	AL(GR 356-T6)	CS(GR WCB)	316 SS(GR CF-8M)
20	VACUUM STEM	316 SS	316 SS	316 SS
21	STUD	SS	SS	SS
22	* COVER GASKET	TFE Teflon®	TFE Teflon®	TFE Teflon®
23	VACUUM PALLET (1) (NOT SHOWN)	316 SS	316 SS	316 SS
24	* VACUUM DIAPHRAGM, PRIMARY (2)(3) (NOT SHOWN)	FEP Teflon®	FEP Teflon®	FEP Teflon®
25	* VACUUM DIAPHRAGM, BACKUP (2) (NOT SHOWN)	FEP Teflon®	FEP Teflon®	FEP Teflon®
26	VACUUM RETAINER PLATE (NOT SHOWN)	316 SS	316 SS	316 SS
27	SEAT INSERT (6"-12" ONLY) (NOT SHOWN)	316 SS	316 SS	316 SS
28	* O-RING (6"-12" ONLY) (3) (NOT SHOWN)	VITON	VITON	VITON
29	SET SCREW (6"-12" ONLY) (NOT SHOWN)	SS	SS	SS
30	VACUUM SCREEN ASSY. (OPTIONAL)	316 SS	316 SS	316 SS
31	SEAT INSERT (2"-4" ONLY) (NOT SHOWN) (4)	N/A	316 SS	N/A
32	PALLET WEIGHT (5) (NOT SHOWN)	LEAD	LEAD	LEAD

* SPARE PARTS

(1) PALLET ALSO AVAILABLE IN ALUMINUM.

(2) TEFLON® IS A REGISTERED TRADEMARK OF E.I. DU PONT DE NEMOURS AND CO. USED UNDER LICENSE.

(3) ELASTOMERS ALSO AVAILABLE IN AFLAS, BUNA-N, EPDM & KALREZ

(4) SEAT: CS UNITS - WELDED

(5) AVAILABLE IN 316 SS; CONSULT FACTORY FOR ALT. MATERIALS.

APPENDIX B: Model 1810A Vacuum Relief Valve

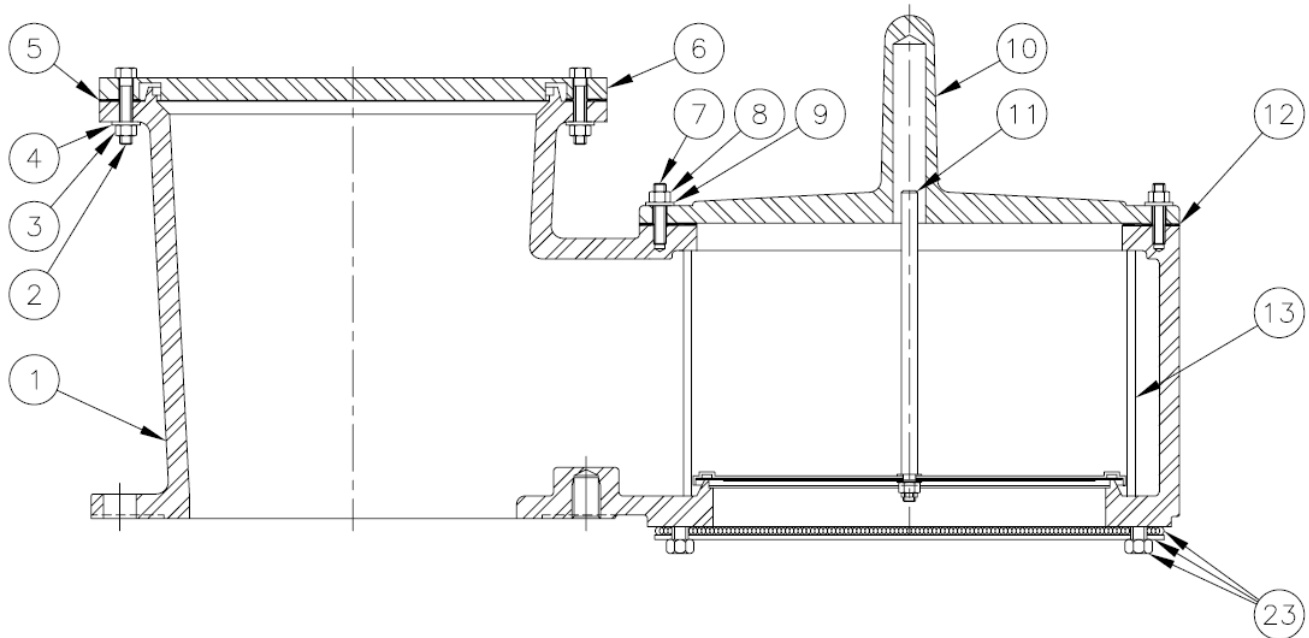

ITEM	DESCRIPTION	STANDARD MATERIALS OF CONSTRUCTION		
		ALUMINUM	CARBON STL	316 SS
1	BODY	AL(GR 356-T6)	CS(GR WCB)	316 SS(GR CF-8M)
2	HEX BOLT	SS	SS	SS
3	HEX NUT	SS	SS	SS
4	LOCK WASHER	SS	SS	SS
5	* INLET GASKET	TFE Teflon®	TFE Teflon®	TFE Teflon®
6	PRESSURE COVER	ALUM	CS	316 SS
7	STUD	SS	SS	SS
8	HEX NUT	SS	SS	SS
9	LOCK WASHER	SS	SS	SS
10	COVER	AL(GR 356-T6)	CS(GR WCB)	316 SS(GR CF-8M)
11	VACUUM STEM	316 SS	316 SS	316 SS
12	* COVER GASKET	TFE Teflon®	TFE Teflon®	TFE Teflon®
13	GUIDE ROD	316 SS	316 SS	316 SS
14	VACUUM PALLET (1) (NOT SHOWN)	316 SS	316 SS	316 SS
15	* VACUUM DIAPHRAGM, PRIMARY (2)(3) (NOT SHOWN)	FEP Teflon®	FEP Teflon®	FEP Teflon®
16	* VACUUM DIAPHRAGM, BACKUP (2) (NOT SHOWN)	FEP Teflon®	FEP Teflon®	FEP Teflon®
17	VACUUM RETAINER PLATE (NOT SHOWN)	316 SS	316 SS	316 SS
18	FLAT WASHER (NOT SHOWN)	SS	SS	SS
19	HEX EXPANDING LOCK NUT (NOT SHOWN)	SS	SS	SS
20	SEAT INSERT (6"-12" ONLY) (4) (NOT SHOWN)	316 SS	316 SS	316 SS
21	* O-RING (6"-12" ONLY) (3) (NOT SHOWN) (NOT SHOWN)	VITON	VITON	VITON
22	SET SCREW (6"-12" ONLY) (NOT SHOWN)	SS	SS	SS
23	VACUUM SCREEN ASSY. (OPTIONAL)	316 SS	316 SS	316 SS
24	SEAT INSERT (4) (NOT SHOWN)	N/A	316 SS	N/A
25	PALLET WEIGHT (5) (NOT SHOWN)	LEAD	LEAD	LEAD

* SPARE PARTS

(1) PALLET ALSO AVAILABLE IN ALUMINUM.

(2) TEFLON® IS A REGISTERED TRADEMARK OF E. I. DU PONT DE NEMOURS AND CO. USED UNDER LICENSE.

(3) ELASTOMERS ALSO AVAILABLE IN AFLAS, BUNA-N, EPDM & KALREZ

(4) SEAT: CS UNITS - WELDED

(5) AVAILABLE IN 316 SS; CONSULT FACTORY FOR ALT. MATERIALS.

APPENDIX C: Model 1820A Pressure/Vacuum Relief Valve

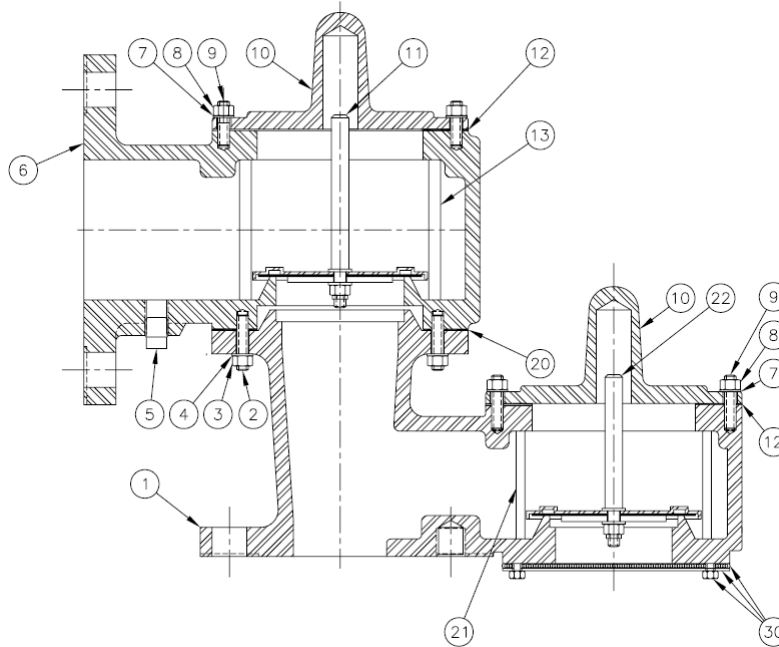

ITEM	DESCRIPTION	STANDARD MATERIALS OF CONSTRUCTION		
		ALUMINUM	CARBON STEEL	316 SS
1	BODY	AL(GR 356-T6)	CS(GR WCB)	316 SS(GR CF-8M)
2	STUD	SS	SS	SS
3	HEX NUT	SS	SS	SS
4	LOCK WASHER	SS	SS	SS
5	PIPE PLUG	316 SS	CS	316 SS
6	OUTLET	AL(GR 356-T6)	CS(GR WCB)	316 SS(GR CF-8M)
7	LOCK WASHER	SS	SS	SS
8	HEX NUT	SS	SS	SS
9	STUD	SS	SS	SS
10	COVER	AL(GR 356-T6)	CS(GR WCB)	316 SS(GR CF-8M)
11	PRESSURE STEM	316 SS	316 SS	316 SS
12	* COVER GASKET	TFE Teflon®	TFE Teflon®	TFE Teflon®
13	GUIDE ROD	316 SS	316 SS	316 SS
14	PRESSURE PALLET (1) (NOT SHOWN)	316 SS	316 SS	316 SS
15	* PRESSURE DIAPHRAGM, PRIMARY (2)(3) (NOT SHOWN)	FEP Teflon®	FEP Teflon®	FEP Teflon®
16	* PRESSURE DIAPHRAGM, BACKUP (2) (NOT SHOWN)	FEP Teflon®	FEP Teflon®	FEP Teflon®
17	PRESSURE RETAINER PLATE (NOT SHOWN)	316 SS	316 SS	316 SS
18	FLAT WASHER (NOT SHOWN)	SS	SS	SS
19	HEX EXPANDING LOCK NUT (NOT SHOWN)	SS	SS	SS
20	* INLET GASKET	TFE Teflon®	TFE Teflon®	TFE Teflon®
21	GUIDE ROD	316 SS	316 SS	316 SS
22	VACUUM STEM (NOT SHOWN)	316 SS	316 SS	316 SS
23	VACUUM PALLET (1) (NOT SHOWN)	316 SS	316 SS	316 SS
24	* VACUUM DIAPHRAGM, PRIMARY (2)(3) (NOT SHOWN)	FEP Teflon®	FEP Teflon®	FEP Teflon®
25	* VACUUM DIAPHRAGM, BACKUP (2)(3) (NOT SHOWN)	FEP Teflon®	FEP Teflon®	FEP Teflon®
26	VACUUM RETAINER PLATE (NOT SHOWN)	316 SS	316 SS	316 SS
27	SEAT INSERT (6"-12" ONLY) (NOT SHOWN)	SS	SS	SS
28	* O-RING (6"-12" ONLY) (3) (NOT SHOWN)	VITON	VITON	VITON
29	SET SCREW (6"-12" ONLY) (NOT SHOWN)	SS	SS	SS
30	VACUUM SCREEN ASSY. (OPTIONAL)	316 SS	316 SS	316 SS
31	SEAT INSERT (2"-4" ONLY) (4) (NOT SHOWN)	N/A	OPTIONAL	N/A
32	PALLET WEIGHT (5) (NOT SHOWN)	LEAD	LEAD	LEAD

* SPARE PARTS

(1) PALLET ALSO AVAILABLE IN ALUMINUM.

(2) TEFLON® IS A REGISTERED TRADEMARK OF E.I. DU PONT DE NEMOURS AND CO. USED UNDER LICENSE.

(3) ELASTOMERS ALSO AVAILABLE IN AFLAS, BUNA-N, EPDM & KALREZ

(4) SEAT: CS UNITS - WELDED

(5) AVAILABLE IN 316 SS; CONSULT FACTORY FOR ALT. MATERIALS.

APPENDIX D: Model 1830A Pressure Relief Valve

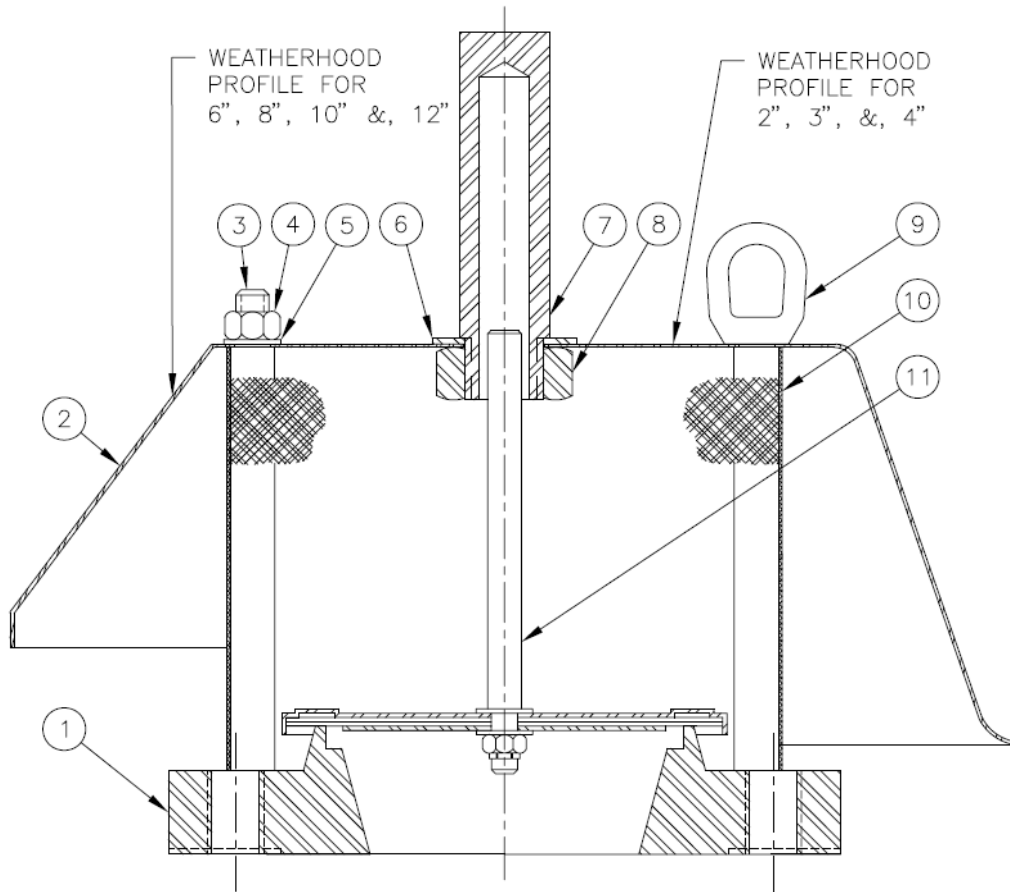

ITEM	DESCRIPTION	STANDARD MATERIALS OF CONSTRUCTION		
		ALUMINUM	CARBON STL	316 SS
1	BASE	AL(GR 356-T6)	CS(GR WCB)	316 SS(GR CF-8M)
2	WEATHER HOOD	ALUM	CS	316 SS
3	WEATHER HOOD POST	316 SS	316 SS	316 SS
4	HEX NUT	SS	SS	SS
5	LOCK WASHER	SS	SS	SS
6	FLAT WASHER	SS	SS	SS
7	STEM GUIDE	ALUM	CS	316 SS
8	HEX JAM NUT	SS	SS	SS
9	EYE NUT (3"-12" ONLY)	SS	SS	SS
10	PRESSURE SCREEN	316 SS	316 SS	316 SS
11	PRESSURE STEM	316 SS	316 SS	316 SS
12	PRESSURE PALLET (1) (NOT SHOWN)	316 SS	316 SS	316 SS
13	* PRESSURE DIAPHRAGM, PRIMARY (2)(3) (NOT SHOWN)	FEP Teflon®	FEP Teflon®	FEP Teflon®
14	* PRESSURE DIAPHRAGM, BACKUP (2) (NOT SHOWN)	FEP Teflon®	FEP Teflon®	FEP Teflon®
15	PRESSURE RETAINER PLATE (NOT SHOWN)	316 SS	316 SS	316 SS
16	FLAT WASHER (NOT SHOWN)	SS	SS	SS
17	HEX EXPANDING LOCK NUT (NOT SHOWN)	SS	SS	SS
18	SEAT INSERT (6"-12" ONLY) (4) (NOT SHOWN)	316 SS	316 SS	316 SS
19	* O-RING (6"-12" ONLY) (3) (NOT SHOWN)	VITON	VITON	VITON
20	SET SCREW (6"-12" ONLY) (NOT SHOWN)	SS	SS	SS
21	SEAT INSERT (2"-4" ONLY) (4) (NOT SHOWN)	N/A	316 SS	N/A
22	PALLET WEIGHT (5) (NOT SHOWN)	LEAD	LEAD	LEAD

* SPARE PARTS

(1) PALLET ALSO AVAILABLE IN ALUMINUM.

(2) TEFLON® IS A REGISTERED TRADEMARK OF E.I. DU PONT DE NEMOURS AND CO. USED UNDER LICENSE.

(3) ELASTOMERS ALSO AVAILABLE IN AFLAS, BUNA-N, EPDM & KALREZ

(4) SEAT: CS UNITS - WELDED

(5) AVAILABLE IN 316 SS; CONSULT FACTORY FOR ALT. MATERIALS.

APPENDIX E: Model 1860A Pressure Relief Valve

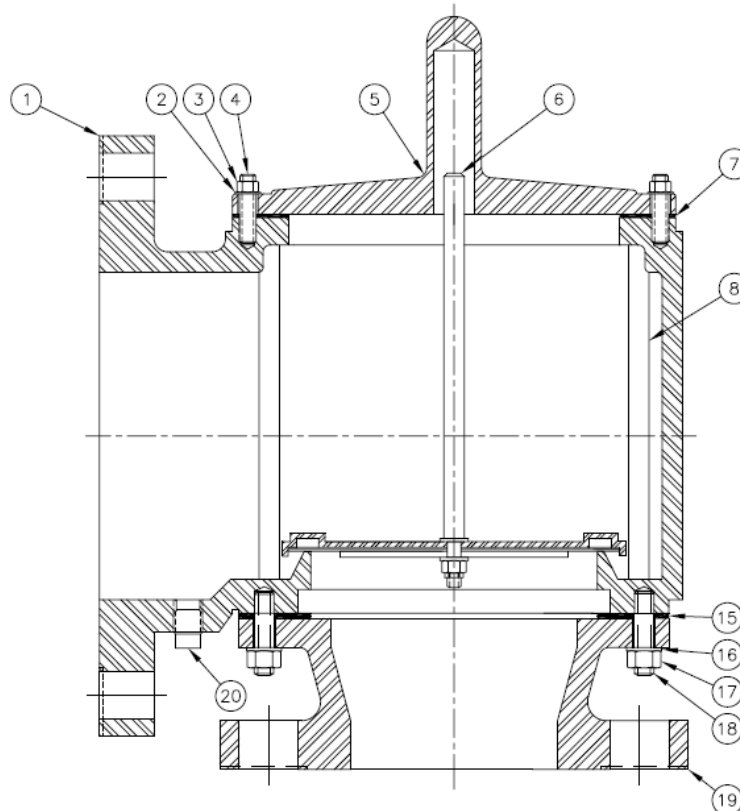

ITEM	DESCRIPTION	STANDARD MATERIALS OF CONSTRUCTION		
		ALUMINUM	CARBON STL	316 SS
1	OUTLET	AL(GR 356-T6)	CS(GR WCB)	316 SS(GR CF-8M)
2	LOCK WASHER	SS	SS	SS
3	HEX NUT	SS	SS	SS
4	STUD	SS	SS	SS
5	COVER	AL(GR 356-T6)	CS(GR WCB)	316 SS(GR CF-8M)
6	PRESSURE STEM	316 SS	316 SS	316 SS
7	* COVER GASKET	TFE Teflon®	TFE Teflon®	TFE Teflon®
8	GUIDE ROD	316 SS	316 SS	316 SS
9	PRESSURE PALLET (1) (NOT SHOWN)	316 SS	316 SS	316 SS
10	* PRESSURE DIAPHRAGM, PRIMARY (2)(3) (NOT SHOWN)	FEP Teflon®	FEP Teflon®	FEP Teflon®
11	* PRESSURE DIAPHRAGM, BACKUP (2) (NOT SHOWN)	FEP Teflon®	FEP Teflon®	FEP Teflon®
12	PRESSURE RETAINER PLATE (NOT SHOWN)	316 SS	316 SS	316 SS
13	FLAT WASHER (NOT SHOWN)	SS	SS	SS
14	HEX EXPANDING LOCK NUT (NOT SHOWN)	SS	SS	SS
15	* INLET GASKET	TFE Teflon®	TFE Teflon®	TFE Teflon®
16	LOCK WASHER	SS	SS	SS
17	HEX NUT	SS	SS	SS
18	STUD	SS	SS	SS
19	INLET	AL(GR 356-T6)	CS(GR WCB)	316 SS(GR CF-8M)
20	PIPE PLUG	316 SS	CS	316 SS
21	SEAT INSERT (6"-12" ONLY) (4) (NOT SHOWN)	316 SS	316 SS	316 SS
22	* O-RING (6"-12" ONLY) (3) (NOT SHOWN)	VITON	VITON	VITON
23	SET SCREW (6"-12" ONLY) (NOT SHOWN)	SS	SS	SS
24	SEAT INSERT (2"-4" ONLY) (4) (NOT SHOWN)	N/A	316 SS	N/A
25	PALLET WEIGHT (5) (NOT SHOWN)	LEAD	LEAD	LEAD

* SPARE PARTS

(1) PALLET ALSO AVAILABLE IN ALUMINUM.

(2) TEFLON® IS A REGISTERED TRADEMARK OF E. I. DU PONT DE NEMOURS AND CO. USED UNDER LICENSE.

(3) ELASTOMERS ALSO AVAILABLE IN AFLAS, BUNA-N, EPDM & KALREZ

(4) SEAT: CS UNITS - WELDED

(5) AVAILABLE IN 316 SS; CONSULT FACTORY FOR ALT. MATERIALS.

APPENDIX F: Model 1870A Vacuum Relief Valve

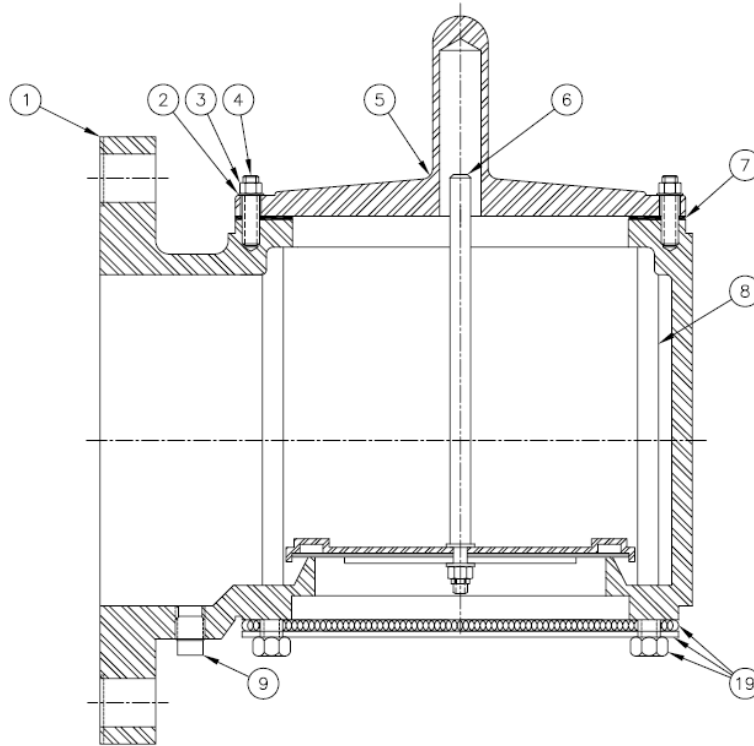

ITEM	DESCRIPTION	STANDARD MATERIALS OF CONSTRUCTION		
		ALUMINUM	CARBON STL	316 SS
1	OUTLET	AL(GR 356-T6)	CS(GR WCB)	316 SS(GR CF-8M)
2	LOCK WASHER	SS	SS	SS
3	HEX NUT	SS	SS	SS
4	STUD	SS	SS	SS
5	COVER	AL(GR 356-T6)	CS(GR WCB)	316 SS(GR CF-8M)
6	VACUUM STEM	316 SS	316 SS	316 SS
7	* COVER GASKET	TFE Teflon®	TFE Teflon®	TFE Teflon®
8	GUIDE ROD	316 SS	316 SS	316 SS
9	PIPE PLUG	316 SS	CS	316 SS
10	VACUUM PALLET (1) (NOT SHOWN)	316 SS	316 SS	316 SS
11	* VACUUM DIAPHRAGM, PRIMARY (2)(3) (NOT SHOWN)	FEP Teflon®	FEP Teflon®	FEP Teflon®
12	* VACUUM DIAPHRAGM, BACKUP (2) (NOT SHOWN)	FEP Teflon®	FEP Teflon®	FEP Teflon®
13	VACUUM RETAINER PLATE (NOT SHOWN)	316 SS	316 SS	316 SS
14	FLAT WASHER (NOT SHOWN)	SS	SS	SS
15	HEX EXPANDING LOCK NUT (NOT SHOWN)	SS	SS	SS
16	SEAT INSERT (8"-14" ONLY) (4) (NOT SHOWN)	316 SS	316 SS	316 SS
17	* O-RING (8"-14" ONLY) (3) (NOT SHOWN)	VITON	VITON	VITON
18	SET SCREW (8"-14" ONLY) (NOT SHOWN)	SS	SS	SS
19	VACUUM SCREEN ASSY, (OPTIONAL)	316 SS	316 SS	316 SS
20	SEAT INSERT (2"-6" ONLY) (4) (NOT SHOWN)	N/A	316 SS	N/A
21	PALLET WEIGHT (5) (NOT SHOWN)	LEAD	LEAD	LEAD

* SPARE PARTS

(1) PALLET ALSO AVAILABLE IN ALUMINUM.

(2) TEFLON® IS A REGISTERED TRADEMARK OF E.I. DU PONT DE NEMOURS AND CO. USED UNDER LICENSE.

(3) ELASTOMERS ALSO AVAILABLE IN AFLAS, BUNA-N, EPDM & KALREZ

(4) SEAT: CS UNITS – WELDED

(5) AVAILABLE IN 316 SS; CONSULT FACTORY FOR ALT. MATERIALS.

Groth Corporation has representatives throughout the world.
Contact Groth Corporation or visit us on the web for the authorized representative in your area.



GROTH CORPORATION

13650 N. Promenade Blvd.
Stafford, TX 77477
Phone: 281-295-6800
FAX: 281-295-6999
Toll-Free: 800-354-7684
E-mail: sales@grothcorp.com
Website: www.grothcorp.com