

TABLE OF CONTENTS:

INTRODUCTION	2
TABLE 1: MAIN ASSEMBLIES	2
INSTALLATION	3
SYSTEM CHECKOUT	3
SAFETY PRECAUTIONS	4
OPERATION INSTRUCTIONS	4
INSPECTION AND MAINTENANCE	5
-AUTOMATIC IGNITION CONTROL	5
-TABLE 2: LAMP INDICATOR	6
-PILOT FUEL SYSTEM	6
-FIGURE 1: AIR INJECTION ASSEMBLY	6
-PILOT FLAME SENSOR	6
-ELECTRODE MAINTENANCE	7
TABLE 3: MAINTENANCE SCHEDULE	7
TROUBLESHOOTING	8
TABLE 4: BOLT TORQUE - MAIN BURNER FLANGE	8
TABLE 5: RECOMMENDED SPARE PARTS	8
BURNER INSPECTION CHECKLIST	9
PRODUCT LIMITED WARRANTY	10
DRAWING 87532: GROTH WASTE GAS BURNER W/ FLANGE MOUNT	11
DRAWING 87533: GROTH WASTE GAS BURNER W/ ANCHOR PLATE	12
DRAWING 94750: AUTO CONTROL PANEL SCHEMATIC	13
DRAWING 87463: AUTO PANEL WIRING DIAGRAM	14
DRAWING 84458: PILOT FUEL MANIFOLD	15
DRAWING 94961: IGNITION ELECTRODE ASSEMBLY	16
DRAWING 84652: MODEL 7622 FLAME CHECK	17

INTRODUCTION:

This manual is intended to provide recommended procedures and practices for installation, operation, and maintenance of the Groth Model 8391B Waste Gas Burner. Any standard procedures and practices developed in a specific plant or process should supersede this manual. Although this manual cannot cover all possible contingencies, following these guidelines should provide safe, reliable Waste Gas Burner performance.

For information not contained in this manual, please contact:

Groth Corporation
13650 Promenade Blvd.
Stafford, TX, 77477
Phone: 281-295-6800
Fax: 281-295-6999

The 8391B Waste Gas Burner with Thermocouple Pilot Flame Sensor consists of seven sub-assemblies, each with a specific function.

SUB-ASSY	FUNCTION
Control Panel	Provide remote control over ignition and pilot fuel system.
Pilot Fuel Supply Manifold	Control fuel supply to pilot burner.
Main Burner/ Windshield	Deliver gas to the discharge nozzle and protect pilot flame from wind conditions.
Ignition Electrode	Provide high voltage spark to ignite pilot gas.
Thermocouple Flame Sensor	Senses that pilot flame is established.
Pilot Burner Assembly	Deliver a combustible mixture of pilot fuel to the ignitor, flame sensor and waste gas discharge nozzle.
Ignition Transformer Assembly	Provide a high voltage source for the ignition electrode.

INSTALLATION:

Mount the flare stack vertically by bolting to a standard ANSI 150# pipe flange with a suitable gasket, or mount the anchor plate with studs in a foundation. Tighten bolts alternately and uniformly. If anchor plate is used, the stack should be leveled and grouted in place. [See Bolt Torque Table 4 pg. 8]

Mount control panel on wall or suitable support structure at the specified minimum distance from the waste gas burner; see drawing C-87532, Page 10 or C-87533, Page 11. The pilot gas line should be a minimum 1/2" ID pipe or tubing.

Connect control panel to ignition transformer box as shown on drawing A-87463, Page 13. The transformer box is grounded to the flare stack. The pilot gas line should be hydrostatically tested according to local codes. At a minimum, the test pressure should be maintained for at least 30 minutes at 1.5 times unregulated supply gas pressure.

The complete piping system must be bubble tight. Inspect the inspirating venturi and gas line to ensure that is free of contaminants such as dirt, insects, nests, etc. prior to installation.

Connect 115/60/1 VAC [or other optional power supply as specified on purchase order] to the control panel following both the National Electric Code and local code guidelines.

Do not attempt to light the pilot until performing the system check-out.

WARNING:

The solenoid valve can freeze in either the open or closed position if exposed to temperatures below 32°F. The valve must either be installed in a protected environment or heat traced and insulated.

SYSTEM CHECK-OUT:

Before a waste gas burner is placed into operation, the complete system must be checked carefully. The check list below may include items that are not included in your system.

Note: Some of these checks have been performed at the factory. However, since a long time period may have occurred between shipment of the equipment and start-up, it is recommended to check all applicable items.

1. Pressure test the pilot gas line.
2. Pressure switch function - isolate switch and raise pressure checking that NO terminal contacts are closed. If control panel is equipped with automatic mode option, check that PILOT GAS ON lamp is illuminated when pressure switch is energized.
3. Solenoid valve function. Supply power and confirm that valve opens; disconnect power to check shut-off.
4. Back-Pressure Regulator [if applicable]. Isolate regulator from system and confirm that regulator opens at desired set pressure.
5. Check Valve - ensure that it is installed in correct flow direction.
6. Connect power supply to control panel. With pilot gas supply closed, check ignition cycle by switching the Control Panel to manual or providing signal from the remote switch. Observe both spark and duration of "spark on" - "spark off" cycles. Refer to operation instructions on page 4.
7. The air injector has been adjusted to the specified gas supply pressure. However, it may be necessary to adjust the air intake plate to optimize the pilot flame. Do NOT remove the Flame Check, drawing C-84652, page 16, which is installed in the gas supply port of the injector.

SAFETY PRECAUTIONS:

1. When burner is operating, all personnel should maintain a safe distance from the unit.
2. The ignition electrode provides a HIGH VOLTAGE DISCHARGE which can cause severe bodily injury or death. DO NOT attempt to service the electrode without first disconnecting and locking out the power supply to the control panel and transformer box.
3. All components on the main burner can be VERY HOT; DO NOT attempt to service any part of the ignition system or pilot assembly until it has cooled. Failure to observe this precaution can cause severe burns.
4. DO NOT SMOKE or use any equipment that could spark while working in the vicinity of the main burner.
5. ALWAYS shut off the gas supply to both the main burner and pilot line before attempting to do any repairs on the system.
6. DO NOT remove or modify the flame check at the pilot gas supply port of the burner, drawing C-84652, page 17.
7. Wiring of the burner must be done according to both National Electric Code and all relevant state and local codes.

OPERATING INSTRUCTION:

The pilot operation is controlled by a MANUAL/OFF/AUTO switch. When the control switch is in the MANUAL position, the pilot control sequence is initiated instantly, and the pilot is ignited and maintained. When the AUTOMATIC position is selected, the pilot control functions on demand and is controlled by a remote switch. A pressure switch is typically provided unless specified otherwise.

Manual: When the "MANUAL" position is selected, pilot fuel is turned on and the ignition electrode begins sparking. The ignition cycle consists of 10 seconds on and 3 seconds off, with pilot fuel remaining on throughout the cycle.

The ignition cycle is repeated until a pilot flame is established. The pilot flame is maintained regardless of flow to the waste gas burner. The 'Pilot Gas On' and 'Pilot Flame On' lights will verify a successful pilot flame.

Automatic: When the "AUTO" position is selected, the pilot control sequence will begin when the remote switch is closed. Normally this is a pressure switch which is installed in the main burner supply line, upstream of the back pressure regulator. It should be set approximately 0.5" - 1" WC below the regulator setting to ensure that the pilot flame will be ignited before gas flows to the main burner. The pilot control is the same as in the manual mode. The burner will continue to operate until the switch condition is interrupted.

Note: The pilot control will respond to the actual supply of waste gas. When the gas pressure drops [due to increased consumption or decreased production], the pressure switch will open and shut off the pilot control. The burner will stay in a "stand-by" mode until gas pressure rises and the pressure switch contact closes which resumes the pilot control sequence.

Options: The Groth Waste Gas Burner has several options from the factory. Please contact the factory for ordering information. The following is a short description of commonly requested options:

Bio-Gas Solenoid Valve: This option is physically connected to a Groth Model 8400A Pressure Relief and Flame Trap Assembly and function is controlled by the Groth Waste Gas Burner Control Panel. The Bio-Gas Solenoid Valve keeps the Model 8400A closed as to not vent bio-gas until the thermocouple senses a proper pilot flame.

Dual Thermocouple (Waste Gas Sensing): A dual thermocouple setup on the Groth Waste Gas Burner provides the ability to sense the pilot flame and the bio-gas flame. The advantage of sensing the bio-gas flame is that when verified, the Control Panel will shut off the pilot gas saving the factory money spent on maintaining a pilot flame via natural gas, propane, etc.

Temperature Controls: The thermocouple [T/C] is in direct contact with the deflector plate. The PILOT T/C OK indicator comes on when the "sensed" temperature exceeds the T/C relay lower switch point [ambient temperature]. This verifies that both thermocouple and monitor are functioning. When the temperature exceeds the T/C relay upper switch point [approx. 800° F.], the PILOT FLAME ON indicator comes on, the ignition cycle is stopped and the pilot continues to burn.

Note: The maximum thermocouple temperature that the pilot flame can achieve is dependent on various factors; pilot fuel, fuel pressure, ambient temperature and wind conditions. The purpose of the thermocouple is not to measure the flame temperature, but to determine if a flame exists. Therefore the upper switchpoint can be adjusted to any temperature which meets the following criteria:

1. *Lower than the temperature achieved by a constant pilot flame under the worst gas and wind conditions.*
2. *Greater than the temperature that can be achieved by ambient conditions or a weak, intermittent or otherwise inadequate pilot.*

The lower switchpoint should be set at approximately ambient temperature.

Burners equipped with a thermocouple [T/C] flame sensor normally take less than 3 minutes, but in some cases may take 10 - 20 minutes to reach the upper switch point. Until that temperature is attained, the ignition cycle will continue. Once established, the pilot will continue to burn, as long as the remote pressure switch energizes the pilot control and power is supplied to the panel. The PILOT GAS ON indicator is illuminated as long as the gas solenoid valve is open.

After a successful ignition, if the pilot flame is extinguished for any reason, the ignition electrode will begin sparking when the "sensed" temperature drops below the upper switch point. Ignition will be attempted as described above.

When ignition is initiated, either manually or automatically, an adjustable time interval begins, typically 10 minutes. If the time interval ends before a pilot flame is established, a flame failure indicator is illuminated on the panel, however the ignition cycle continues. Additional contacts are provided for a remote alarm signal if desired.

The flame failure interval should be set to provide the normal T/C heat-up time plus 20% to avoid nuisance alarm signals.

If the *Auto Shut Down / Manual Reset* option is chosen, the ignition system will shut down after a pilot flame failure indication. The system is manually reset at the control panel by turning the selector switch to OFF and then returning it to AUTO or MANUAL. This option is enabled by removing the internal jumper between terminals 5 and 8.

INSPECTION AND MAINTENANCE:

To ensure safe operation of your complete burner system, the following items need to be inspected periodically. See table 3, page 7 for suggested maintenance intervals. Follow your own plant safety guidelines before performing the inspection. We recommend the following:

MINIMUM SAFETY PROCEDURES

1. **Disconnect and lock-out electric power to the control panel.**
2. **Shut off the supply of gas to the pilot line and lock-out.**
3. **Allow burner to cool to ambient temperatures or take precautions to deal with metal parts that are exposed to the pilot and main burner flames.**

AUTOMATIC IGNITION CONTROL

1. Open the ignition control panel enclosure door and check the condition of wiring, relays, switches, and the flame monitor equipment. Look for evidence of loose wires at connections, burned components, loose enclosures on relays, moisture, dirt or foreign materials, etc. Make sure that the proper range is selected on all time delay relays. 1TR should be set for 10 seconds on and 3 seconds off. 2TR is typically set for 5-10 minutes but may be longer [see operating instruction].
2. Open the transformer enclosure door and make sure the high voltage lug connection on the transformer is tight. Check for loose wires, moisture, dirt or foreign materials, etc.
3. Remove the junction box cover from the electrode and disconnect the ignition wire and flexible conduit. Remove [2] U-bolts and remove the electrode from the burner [see electrode maintenance]. Handle the

electrode with care because the internal ceramic insulators can be easily damaged. When replacing, make sure the electrode housing is approximately 1/10" below the deflector angle at the top of the burner.

After the inspection has been completed, power and pilot gas should be restored to the unit. Then check the following operational items:

1. Turn the selector switch to the "MANUAL" position.
2. You should be able to hear the electrode arcing at the top of the pilot gas assembly. This should continue for 10 seconds. If no flame is established there will be a 3 second delay before the electrode will repeat the ignition part of the cycle. When the pilot is ignited, turn the selector switch to the "OFF" position. All panel lamps have a "Push-to-test" feature to verify that the bulbs are functional. Refer to Table 2.

TABLE 2 LAMP INDICATOR	
LAMP COLOR	INDICATOR
Green	T/C Monitor OK
Green	Pilot Flame ON
Yellow	Pilot Gas On
Red	Pilot Flame Failure

PILOT FUEL SYSTEM

1. Shut off the supply of gas to the pilot line and lock-out.
2. Disconnect fuel supply to air injector at "Gas Inlet", Fig. 1.
3. Remove air injector body at "Mixture Outlet".
4. Inspect "Orifice Spud". Diameter may vary from 0.03" to 0.13" depending on fuel pressure. Clean with small wire or compressed air if necessary.

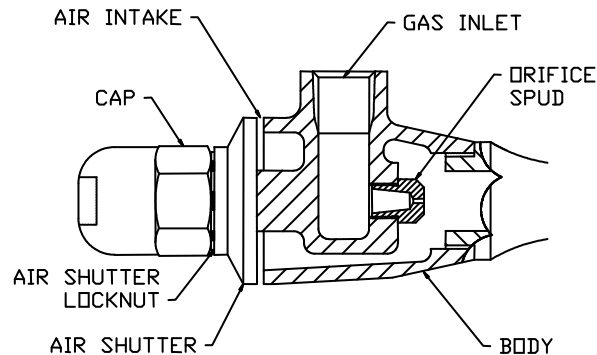

Figure 1 - Air Injection Assembly

5. Blow compressed air into bottom of pilot burner pipe to remove any foreign material from pipe or nozzle.
6. Replace air injector body and fuel supply connection.
7. Before lighting pilot, apply pressure and test all fuel supply connections with a soap solution.

PILOT FLAME SENSOR

1. Open the control panel cover and observe the digital display on the Omron temperature controller. The thermocouple temperature should be displayed in the upper right corner of the screen. If the pilot is not burning, it should display approximately ambient temperature. The upper switch point temperature setting should be displayed in the lower right corner.
2. Relay switch status is displayed in the upper left corner. A display [ALM1 or ALM2] indicates the switch is activated. Both switches are NO so a display means the contacts are closed. ALM1 should be displayed at anytime the power is on. ALM2 should be displayed if the temperature [upper right] is equal to or greater than the set temperature [lower right].

3. If any of these displays are incorrect, there is a problem with the thermocouple or the controller. If a thermocouple signal is not input, a flashing ERR signal will be displayed in the upper right position.
5. If the thermocouple is defective, remove the thermowell assembly from the burner structure by removing (2) 1/2" U-bolts. A new thermocouple assemble can be installed or a new thermocouple can be inserted into the thermowell. Make sure that the spring is forcing the thermocouple to contact the end of the thermowell. Always maintain the proper polarity when connecting thermocouples. Type K (Yellow + , Red -)

ELECTRODE MAINTENANCE

[See drawing B-94961, page 16]

1. Remove the hex nut [18] and push the hex nut [16] in to pipe. Slide the shield [19] down the pipe to expose the set spacer.
2. Remove the hex bolt and the spacer [17]. Remove the set screws in the conduit connector [8] and pull the spark disc assembly [1,2,5,7,9,14 & 15] from the pipe. Inspect the spark disc and clean or replace as necessary. Inspect the ceramic insulators [7] for damage. Replace if necessary.
3. Assemble as shown in drawing B-94961, then slide the complete assembly into the pipe. All connections must be tight. Do not use Teflon tape or any other insulating material on connections.
4. Screw in set screws in conduit connector [8].
5. Install the spacer and shield over the set screw, then back the set screw out and install the locknut.

TABLE 3 - MAINTENANCE SCHEDULE

The following items should be inspected according to the schedule listed below:

COMPONENT	INSPECTION INTERVAL	MAINTENANCE ACTION REQUIRED
Pilot Flame	1 month	Inspect while burning to confirm that optimum flame is achieved. Adjust air intake shutter as required.
Ignition Electrode	1 month	Check electrode function. [see Electrode Maintenance]
Pilot Gas Line Filter	1 month	Record Differential Pressure and replace cartridge before pilot supply is restricted.
Solenoid Valve [Pilot gas shut-off]	1 month	Check solenoid function to ensure valve is opening and closing properly
Pilot Nozzle	6 months	Inspect for deterioration due to corrosion and replace as required.
Wiring Connections to Electrodes	6 months	Replace wire and connectors if damaged.
Pressure Switch Dwyer 1950-20	6 months	Clean the switch and turn the vent drain plug one turn CW, then return to standard position
Ignition Electrode	12 months	Inspect for deterioration due to corrosion & High temperature and replace as required.

TROUBLESHOOTING

Failure to achieve Pilot Flame Ignition may be caused by:

1. Loss of AC power to panel ("POWER ON" light is off.)
2. Fuse may have burned out. [5 amp]

3. Pilot gas supply shutoff or low pilot gas supply pressure.
4. Restriction in pilot gas supply line or inspirator air intake. Inspiring venturi nozzle is factory drilled according to the pilot gas pressure specified on order. Strainer or filter cartridge may be plugged; clean or replace as required.
5. Ignition component failure:
 - a. Electrode shorting to ground
 - b. Spark disc failure
 - c. Transformer failure
 - d. Poor electrical connection between transformer and electrode
 - e. Failure of relay which powers ignition transformer
 - f. Carbon/soot build-up on ignition electrode tip
6. Utilize the "Push-to-test" capability of the panel lamps to check the condition of the bulbs.

TABLE 4 BOLT TORQUE MAIN BURNER FLANGE ⁽¹⁾	
BOLT SIZE	BOLT TORQUE [Ft. - Lb.]
5/8" - 11 UNC	110
3/4" - 10 UNC	200
7/8" - 9 UNC	320

⁽¹⁾ It is assumed that studs and nuts are plated and torqued without lubricants.

TABLE 5 RECOMMENDED SPARE PARTS ⁽¹⁾		
QTY	PART NUMBER	DESCRIPTION
1	604003900	Transformer, Ignition
1	IEA8391	Electrode, Ignition ⁽²⁾
1	604004100	Insulated Connector
1	604004200	Wire, Ignition
1	TCP839101S0	Thermocouple, pilot
1	OSP839154XX	Orifice Spud ⁽³⁾
2	347320X51	Pressure Gauge ⁽³⁾
1	3574000F2	Y-Strainer
1	604003500	Filter, Cartridge
1	359400001	Valve, Solenoid
1	112000500	Temperature controller

⁽¹⁾ When ordering, specify pilot gas and supply pressure.

⁽²⁾ Damaged electrodes may be returned to Groth Corporation for a complete rebuild. Spare parts are also available for electrode repair.

⁽³⁾ P/N may vary, please specify pilot gas and supply pressure for proper sizing.

Groth Waste Gas Burner Onsite Inspection Checklist

Model No.:		
Serial No.:		
Factory Thermocouple Set Point:		
Factory Timer Settings:		
Factory Pilot Fuel Pressure:		
Factory Pressure Switch Setting:		
Inspection Point	√	Comments
Panel lights		
Internal components in place		
Auto mode functional test		
Manual mode functional test		
Thermocouple temperature operation		
Temperature switch point		
Time delay settings		
Panel heater temperature		
Audible alarm function		
Pilot fuel pressure		
Gage function		
Solenoid valve function		
Pilot flame quality		
Main flame quality		
Customer wiring to specification		
Pressure Switch Set Point Verified		
Burner condition [heat, corrosion, contamination]		
General Installation Notes:		
Groth Associate:	Date:	
Authorized Contractor Representative:	Date:	

PRODUCT LIMITED WARRANTY

- A. Seller warrants that products which are manufactured by Seller, are manufactured in accordance with published specifications and free from defects in materials and/or workmanship for a period of (12) twelve months. Seller, at its option, will repair or replace any products returned intact to the factory, transportation charges prepaid, which Seller, upon inspection, shall determine to be defective in material and/or workmanship. The foregoing shall constitute the sole remedy for any breach of Seller's warranty.
- B. THERE ARE NO UNDERSTANDINGS, AGREEMENTS, REPRESENTATIONS, OR WARRANTIES, EXPRESS OR IMPLIED, (INCLUDING MERCHANTABILITY OR FITNESS FOR A PARTICULAR PURPOSE REGARDING PRODUCTS) UNLESS SPECIFIED IN THE SALES CONTRACT . THIS CONTRACT STATES THE ENTIRE OBLIGATION OF SELLER.
- Seller makes no warranties, either express or implied, except as provided herein, including without limitation thereof,
- warranties as to marketability, merchantability, for a particular purpose or use, or against infringement of any patent of products. In no event shall Seller be liable for any direct, incidental or consequential damages of any nature, or losses or expenses resulting from any defective new product or the use of any such product, including any damages for loss of time, inconvenience, or loss of use of any such product.
- C. The original Manufacturer shall be solely responsible for the design, development, supply, production, and performance of its products hereunder, and the protection of its trade name or names, if any. It assumes no responsibility, for products modified or changed in any way by its agent or customer. Any such modifications or changes to products sold by Seller hereunder shall make the product limited warranty null and void.
- D. The Manufacturer shall be under no obligation to manufacture, sell, or supply, or to continue to manufacture, sell or supply any of the Products.

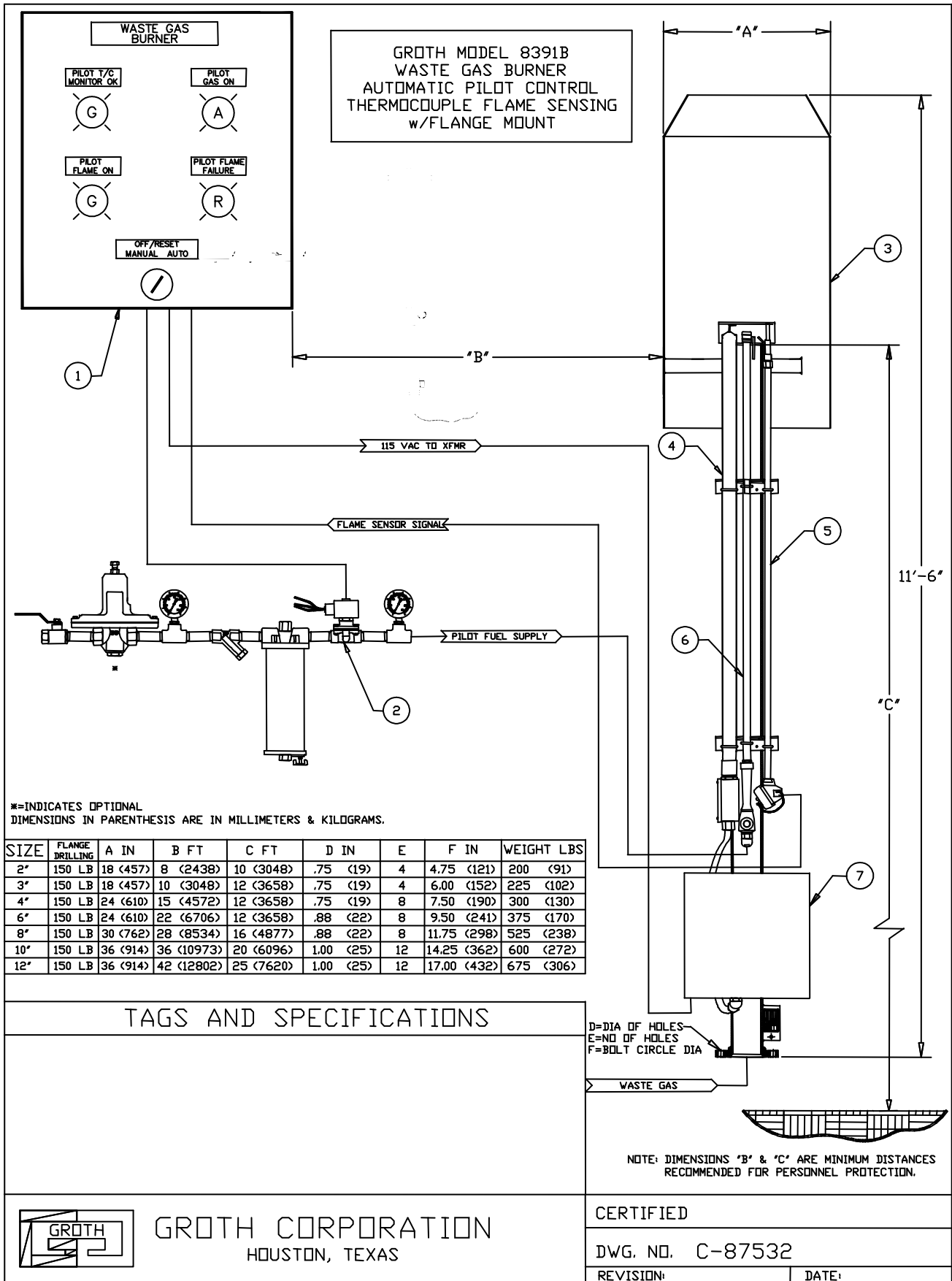

GROTH MODEL 8391B
WASTE GAS BURNER
AUTOMATIC PILOT CONTROL
THERMOCOUPLE FLAME SENSING
w/FLANGE MOUNT

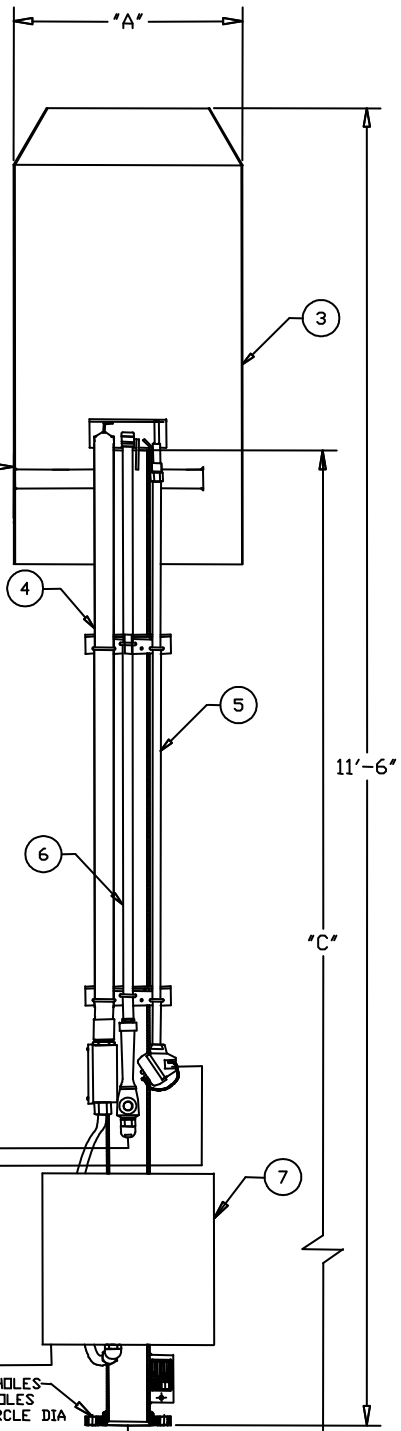
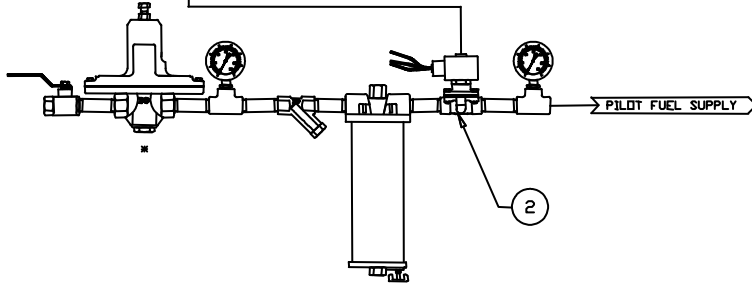
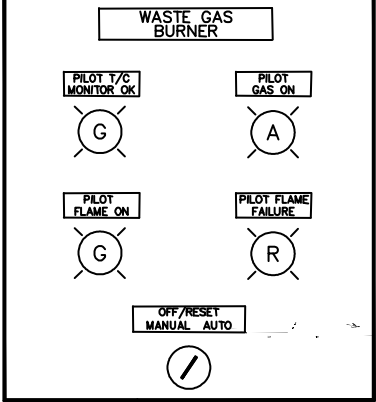

*=INDICATES OPTIONAL
DIMENSIONS IN PARENTHESIS ARE IN MILLIMETERS & KILOGRAMS.

SIZE	FLANGE DRILLING	A IN	B FT	C FT	D IN	E	F IN	WEIGHT LBS
2"	150 LB	18 (457)	8 (2438)	10 (3048)	.75 (19)	4	4.75 (121)	200 (91)
3"	150 LB	18 (457)	10 (3048)	12 (3658)	.75 (19)	4	6.00 (152)	225 (102)
4"	150 LB	24 (610)	15 (4572)	12 (3658)	.75 (19)	8	7.50 (190)	300 (130)
6"	150 LB	24 (610)	22 (6706)	12 (3658)	.88 (22)	8	9.50 (241)	375 (170)
8"	150 LB	30 (762)	28 (8534)	16 (4877)	.88 (22)	8	11.75 (298)	525 (238)
10"	150 LB	36 (914)	36 (10973)	20 (6096)	1.00 (25)	12	14.25 (362)	600 (272)
12"	150 LB	36 (914)	42 (12802)	25 (7620)	1.00 (25)	12	17.00 (432)	675 (306)

TAGS AND SPECIFICATIONS

D=DIA OF HOLES
E=NO OF HOLES
F=BOLT CIRCLE DIA

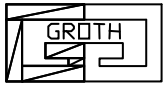

GROTH CORPORATION
HOUSTON, TEXAS

CERTIFIED	
DWG. NO. C-87532	
REVISION:	DATE:

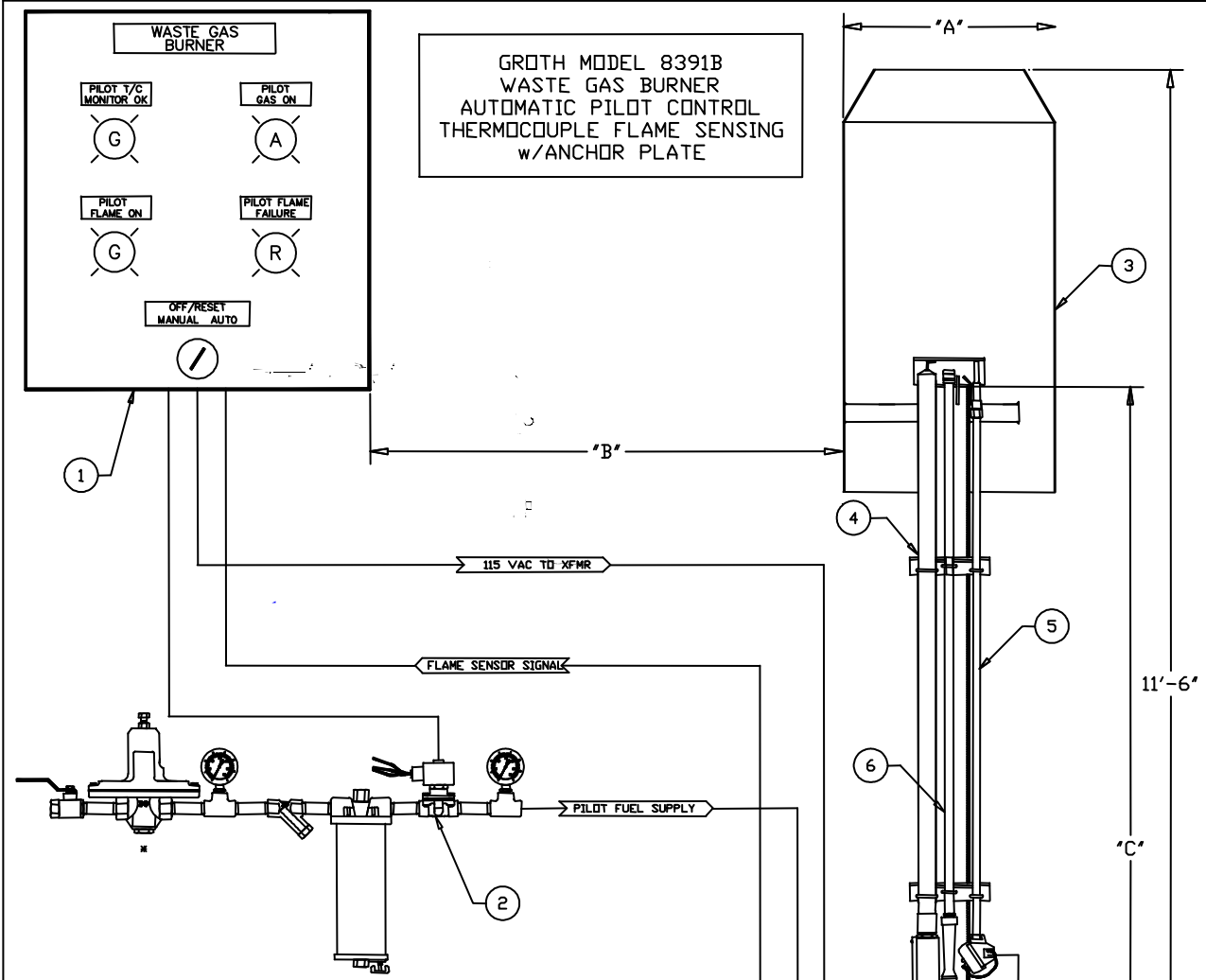

*=INDICATES OPTIONAL
 DIMENSIONS IN PARENTHESIS ARE IN MILLIMETERS & KILOGRAMS

SIZE	A IN	B FT	C FT	D IN	E IN	WEIGHT LBS
2"	18 (457)	8 (2438)	10 (3048)	11 (279)	14 (356)	200 (91)
3"	18 (457)	10 (3048)	12 (3658)	12.50 (317)	15.50 (392)	225 (102)
4"	24 (609)	15 (4572)	12 (3658)	14 (356)	17 (432)	300 (130)
6"	24 (609)	22 (6706)	12 (3658)	17 (432)	20 (508)	375 (170)
8"	30 (762)	28 (8534)	16 (4877)	22 (559)	25 (635)	525 (238)
10"	36 (914)	36 (10973)	20 (6096)	27 (686)	30 (762)	600 (272)
12"	36 (914)	42 (12802)	25 (7620)	27 (686)	30 (762)	675 (306)

TAGS AND SPECIFICATIONS

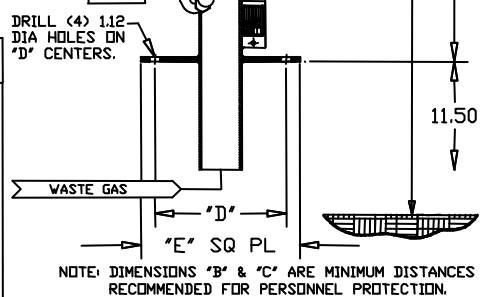

GROTH CORPORATION
 HOUSTON, TEXAS

CERTIFIED
 DWG. NO. C-87533
 REVISION: _____ DATE: _____

PART NO.	DESCRIPTION
94750	ENCLOSURE AND OPTIONS ARE DESIGNATED BY A SUFFIX TO THE DRAWING NUMBER AS NOTED:

- NOTE: 1. FOR INTERCONNECTION DIAGRAM SEE DWG 87463 FOR CONTROL PANEL ASSY, NEMA 4 & 4X, SEE DWG B-85820 FOR CONTROL PANEL ASSY, NEMA 7, SEE DWG B-94766
2. EQUIPMENT TERMINAL
CONTROL PANEL TERMINAL
TRANSFORMER BOX TERMINAL
3. GAS SOLENOID VALVE IS OPEN WHEN ENERGIZED.
4. WIRING BY GROTH:
WIRING BY OTHERS
- 0 = NO OPTION
1 = AUTO SHUT DOWN/MANUAL RESET
- 0 = NO OPTION
1 = PANEL HEATER
2 = ALARM (AUDIBLE)
3 = ALARM (VISUAL)
4 = STEP-DOWN XFMR

- 0 = NO OPTION
1 = AUTO SHUT DOWN/MANUAL RESET
- 1 = NEMA 4 CARBON STEEL
5 = NEMA 4X 316 SS
7 = NEMA 7 ALUMINUM
8 = NEMA 4X FIBERGLASS
9 = NEMA 4X 304 SS

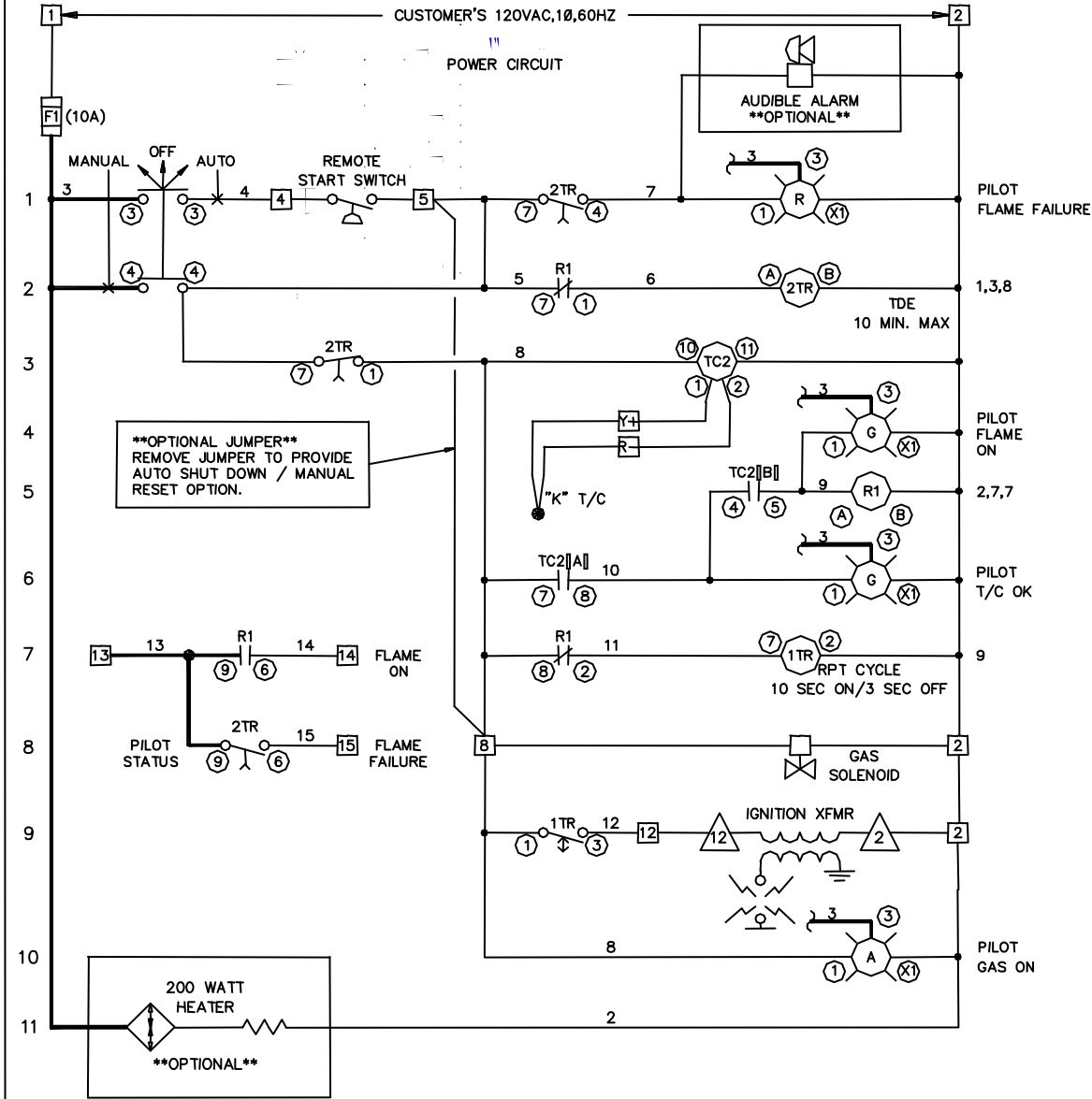

GROTH CORPORATION
HOUSTON, TEXAS

SCALE: NTS
DATE: 12-27-06
CHECKED BY: NTS
APPROVED BY: [Signature]

DISK NO: [Blank]
DRAWING NUMBER: A-94750

REV: [Blank] DATE: [Blank] BY: [Blank]

THIS DRAWING EMPHATICALLY REPRESENTS A CONFIDENTIAL, PROPRIETARY DESIGN AND IS THE PROPERTY OF GROTH CORPORATION. NO REPRODUCTION, REPRODUCTION, USE AND SALE RIGHTS, REGARDING THE SAME ARE EXPRESSLY RESERVED. IT IS SUBMITTED UNDER A CONFIDENTIAL RELATIONSHIP FOR A SPECIFIC PURPOSE, AND THE RECIPIENT AGREES TO ACCEPT THIS DRAWING AS A CONFIDENTIAL DESIGN AND TO MAINTAIN IT AS SUCH. ANY REPRODUCTION OR USE OF THIS DRAWING FOR ANY OTHER PROJECTS WITHOUT THE WRITTEN PERMISSION OF GROTH CORPORATION IS STRICTLY PROHIBITED. ALL PATENTS RIGHTS HERETO ARE EXPRESSLY RESERVED BY GROTH CORPORATION, 1202 HAHLO, HOUSTON, TEXAS 77020

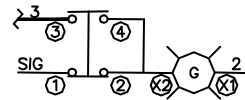

PUSH-TO-TEST LAMP
TYP INTERNAL CONN

WGB CONTROL PANEL

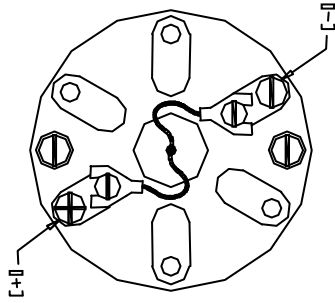
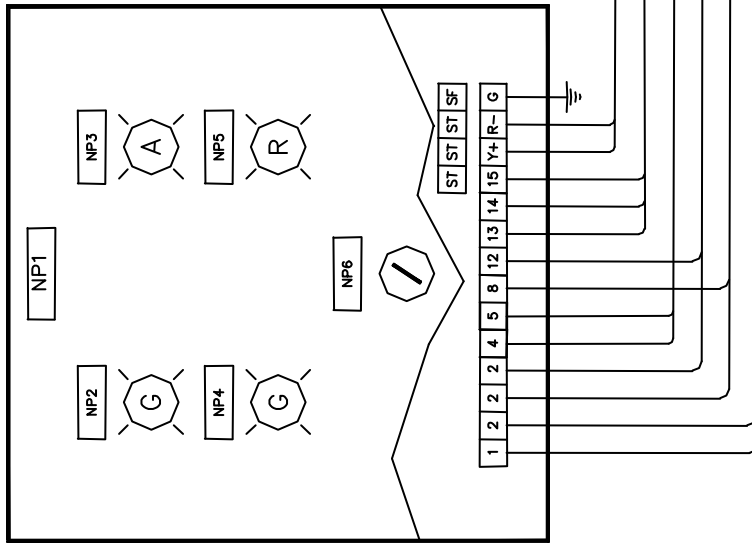

DETAIL Z-Z
THERMOCOUPLE CONNECTION TERMINALS
CONNECT TYPE "K" THERMOCOUPLE WIRE
YELLOW TO [+] TERMINAL SCREW
RED TO [-] TERMINAL SCREW

THERMOCOUPLE CABLE
PILOT FLAME STATUS
REMOTE START SWITCH
IGNITION TRANSFORMER
PILOT GAS SOLENOID
120VAC POWER

- NOTE: (1) CONNECT TYPE "K" THERMOCOUPLE LEAD WIRES TO APPROPRIATE TERMINALS BLOCKS
(1) - SIG(+) - YELLOW WIRE
(2) - SIG(-) - RED WIRE.
(2) RUN THERMOCOUPLE CABLE IN SEPARATE CONDUIT
(3) FOR CONTROL SCHEMATIC SEE DWG 94750
FOR CONTROL PANEL ASSY SEE DWG B-85820 (C)

NAMEPLATE SCHEDULE	
NP#	2nd LINE
1	WASTE GAS BURNER
2	PILOT T/C MONITOR OK
3	PILOT GAS ON
4	PILOT FLAME ON
5	PILOT FLAME FAILURE
6	OFF/RESET MANUAL AUTO

WIRING BY GROTH CORP.
WIRING BY OTHERS - OPTIONAL
WIRING BY OTHERS

AUTOMATIC IGNITION CONTROL

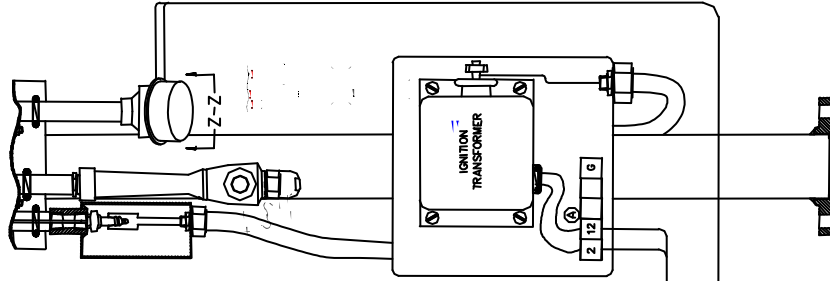

GROTH CORPORATION HOUSTON, TEXAS	
SCALE: NTS	CHECKED BY: []
DATE: 8-3-95	APPROVED BY: []
DRAWN BY: CFS	
DISK NO: J	
PANEL WIRING DIAGRAM, AUTO, 8391B	
TOL UNLESS OTHERWISE SPECIFIED	FRACTIONAL DECIMALS ANGLES DRAWING NUMBER
—	— x ±.03 1/2° ±.010 A-87463

REV	DATE	BY	DESCRIPTION
C	5-31-97	CS	
B	8-18-95	CS	
A	7-16-95	SC	97069

THIS DRAWING EMBODIES A CONFIDENTIAL PROPRIETARY DESIGN, MANUFACTURING REPRODUCTION USE AND SALE RIGHTS, REGARDING THE SAME ARE EXPRESSLY RESERVED. IT IS SUBMITTED UNDER A CONFIDENTIAL RELATIONSHIP BY ACCEPTING THIS DESIGN AND THE SUPPLY THEREOF. ANY INFORMATION REGARDING IT TO ANY UNAUTHORIZED PERSONS OR TO INCORPORATE IN OTHER PROJECTS ANY SPECIAL FEATURES PECULIAR TO THIS DESIGN, ALL PATENTS AND TRADEMARKS ARE THE PROPERTY OF GROTH CORPORATION, 1000 W. HILTON, HOUSTON, TEXAS 77060

MODEL 8391A
WASTE GAS BURNER
PILOT FUEL MANIFOLD

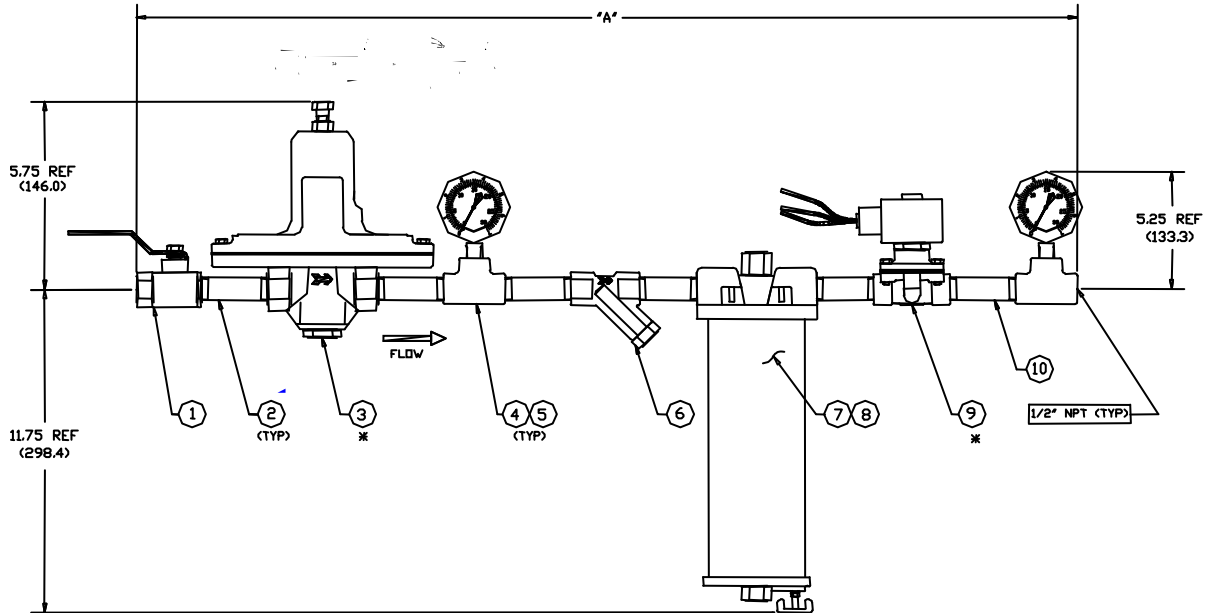

OPTIONS	A
w/ITEMS 3 & 9	35.25 (895.3)
w/ITEM 3	30.25 (768.3)
w/ITEM 9	28.68 (728.4)
w/o ITEMS 3 & 9	23.63 (600.2)

DIMENSIONS IN PARENTHESIS ARE IN MILLIMETERS
NOTE: (*)=ITEM NO. 3 & 9 ARE OPTIONAL,
PILOT FUEL MANIFOLD TO BE
INSTALLED BY OTHERS.

TAGS AND SPECIFICATIONS

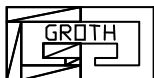

GROTH CORPORATION
HOUSTON, TEXAS

CERTIFIED

DWG. NO. C-84458

REVISION: C

DATE: 07-18-97

MODEL 7622
FLAME CHECK

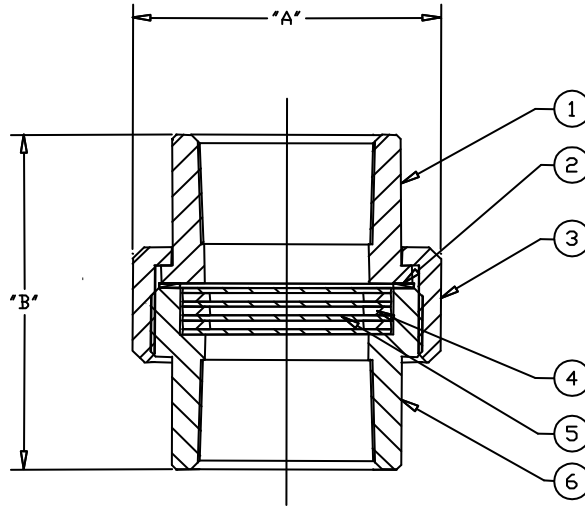

SIZE	A	B
1/2" (*)	1.88 (47.7)	4.30 (109.2)
3/4"	1.88 (47.7)	1.88 (47.7)
1"	2.13 (54.1)	2.38 (60.4)
1 1/4"	2.50 (63.5)	2.63 (66.8)
1 1/2"	3.00 (76.2)	3.00 (76.2)
2"	4.13 (104.9)	3.50 (88.9)

NOTE: DIMENSIONS IN PARENTHESIS ARE IN MILLIMETERS.
(*)=1/2" SIZE USES REDUCER BUSHING.

TAGS AND SPECIFICATIONS



GROTH CORPORATION
HOUSTON, TEXAS

CERTIFIED

DWG. NO. C-84652

REVISION:

DATE: