

TABLE OF CONTENTS:

INTRODUCTION	2
DESIGN, FUNCTION & OPERATION	2
GENERAL SAFETY INSTRUCTIONS	3
SAFETY WARNINGS	3
INSPECTION AND INSTALLATION	4
TABLE 1: INLET/OUTLET FLANGE GASKET DIMENSIONS	5
TABLE 2: BOLT TORQUE	5
OPERATION	6
TABLE 3: SPRING TABLE	6
TROUBLESHOOTING GUIDE	7
PREVENTATIVE MAINTENANCE	7
RECOMMENDED SPARE PARTS	7
TABLE 4: SOFT GOODS KITS	7
FIGURE 1: GROTH MODEL 8860 BACK PRESSURE REGULATOR 2"-8"	8
TABLE 5: MODEL 8860 BILL OF MATERIALS 2"-8"	9
FIGURE 2: GROTH MODEL 8860 BACK PRESSURE REGULATOR 10"-12"	10
TABLE 6: MODEL 8860 BILL OF MATERIALS 10"-12"	11
MODEL INFORMATION	12
PRODUCT LIMITED WARRANTY	12

INTRODUCTION:

The Groth Model 8860 Back Pressure Regulator controls upstream pressure in a process line such as an anaerobic digester gas control system. The pressure setting is obtained by adjustable spring compression and opening is caused by upstream pressure acting on a large diaphragm. A visible scale indicates approximate set pressure. Springs are available for various standard and special set pressure ranges.

The regulator must be maintained by a knowledgeable valve technician. It should only be assembled under clean conditions, preferably in a shop environment. Carefully read and understand this manual before attempting to adjust set pressure or flow capacity, or repair the regulator.

For information not contained in this manual, please contact:

Groth Corporation
13650 Promenade Blvd.
Stafford, TX, 77477
Phone: 281-295-6800
Fax: 281-295-6999

DESIGN, FUNCTION & OPERATION:

The Groth Model 8860 Back Pressure regulator is a high capacity, low pressure in-line pressure relief valve. It controls upstream pressure by discharging excess vapor downstream.

When the diaphragm force, due to upstream pressure, equals the spring compression, the regulator begins to open. Opening is controlled to accommodate the required vapor flow. Full capacity is achieved at 15-25% over-pressure [above set pressure]. When system pressure returns to set pressure or below, the regulator closes.

Upstream vapor pressure, acting on a large diaphragm, forces the regulator open at the specified set pressure. For best performance, set pressure should be sensed at a remote location at least ten pipe diameters upstream from the regulator. The upstream pressure acts on the lower surface of the diaphragm. The upper side of the diaphragm must be vented to atmosphere.

Set pressure is determined by the compression of the spring; the greater the compression of the spring, the higher line pressure required to overcome the spring force. The scale located on the regulator is a close approximation of the set pressure. A manometer is recommended for a high accuracy reading of the set pressure. The manometer should be plumbed upstream of the Back Pressure Regulator, at least ten pipe diameters.

The seat and disc are lapped flat surfaces with metal to metal contact.

GENERAL SAFETY INSTRUCTIONS

This section is intended as an overview of safety guidelines that should be followed during the installation, operation and maintenance of the Groth Model 8860 Back Pressure Regulator. To understand the context of these warnings and instructions, read and understand this complete manual.

SAFETY WARNINGS

IN THE EVENT OF AN ACTUATOR DIAPHRAGM FAILURE, THE REGULATOR WILL FAIL IN THE CLOSED POSITION. VAPOR FLOW WILL BE SHUT OFF. WITHOUT PROPER PIPELINE PRESSURE SENSING, EXCESSIVE PRESSURE CAN BE REACHED.

REGULATOR FLOW CAPACITY IS BASED ON A FULLY OPEN REGULATOR FLOWING AIR OR A VAPOR WITH SG=0.7. CONSULT FACTORY FOR CAPACITY UNDER OTHER CONDITIONS.

DO NOT ATTEMPT TO RE-ADJUST THE SET PRESSURE BEYOND THE LIMITS SPECIFIED IN TABLE 3.

THE REGULATOR IS TO BE CONNECTED TO THE UPSTREAM LINE WITH A MINIMUM 0.31" ID TUBING SENSE LINE. THIS LINE MUST BE KEPT OPEN AND UNOBSTRUCTED TO ENSURE THAT THE REGULATOR SENSES THE ACTUAL LINE PRESSURE. LONG SENSE LINES MAY REQUIRE A LARGER DIAMETER AND CARE MUST BE TAKEN DURING INSTALLATION TO ASSURE THAT THE LINE IS SELF-DRAINING.

DO NOT ATTEMPT TO REMOVE THE REGULATOR FROM THE LINE OR PERFORM FIELD REPAIRS IN LINE WITHOUT FIRST ISOLATING THE REGULATOR FROM BOTH UPSTREAM AND DOWNSTREAM SYSTEMS.

THE REGULATOR BODY AND ACTUATOR HOUSING ARE EXPOSED TO PROCESS VAPORS. OBSERVE ALL SAFETY PRECAUTIONS AS SPECIFIED ON THE MATERIAL SAFETY DATA SHEET(S) FOR THE PRODUCT(S) THAT ARE IN THE SYSTEM.

THE VENT ON THE UPPER ACTUATOR HOUSING MUST BE CLEAN AND OPEN TO THE ATMOSPHERE AND SHALL BE INSPECTED PERIODICALLY.

THE RECOMMENDED SET PRESSURE RANGE OF THE REGULATOR SPRING IS STAMPED ON THE NAMEPLATE. NEVER ADJUST A SPRING FOR A SET PRESSURE BEYOND ITS DESIGN RANGE AS SPECIFIED IN TABLE 3. EXCEEDING THE SPRING UPPER LIMIT MAY COMPRESS THE SPRING TO ITS SOLID HEIGHT, AND PREVENT THE REGULATOR FROM OPENING. SETTING IT BELOW THE LOWER LIMIT MAY PREVENT THE REGULATOR FROM CLOSING FULLY AT THE REQUIRED PRESSURE.

PROCESS PIPING IS TO BE CLEAN AND FREE OF WELD SLAG. WELD SLAG OR OTHER DEBRIS COULD BLOCK THE SENSE LINE OR DAMAGE THE REGULATOR SEATING SURFACE.

DO NOT LIFT THE BACK PRESSURE REGULATOR FROM THE ADJUSTMENT SCREW. IF LIFTED FROM THIS LOCATION, THE ADJUSTMENT SCREW MAY BE PERMANENTLY DAMAGED.

USING AN IMPROPER PRESSURE SENSING LINE CAN RESULT IN LIMITED OR NO FUNCTIONALITY OF THE REGULATOR. RECOMMENDED SIZE FOR THE PRESSURE SENSING LINE IS AT LEAST 0.31". THIS LINE MUST REMAIN FREE OF DEBRIS AND ANY TYPE OF OBSTRUCTION.

INSPECTION AND INSTALLATION

The regulator is packaged and supported to prevent damage or contamination during shipment. The regulator shall also be protected during subsequent handling and storage. Always keep all ports plugged to prevent intrusion of foreign materials. Before installation, inspect the unit visually. If there are indications of physical damage or internal contamination, the regulator must be disassembled, cleaned and inspected before installation. If factory set, the spring adjustment cap must be secure. Report any shipping damage to carrier.

The regulator must be installed in a horizontal line as shown in Figure 1. Use the actuator housing or valve body to lift and support the regulator at installation.

1. Aluminum bodies should be connected with flat-faced 150# ANSI flanges using a full-faced gasket. Mating flanges should be flat within 0.020", clean, free of scratches, corrosion and tool marks.
2. Steel bodies should be connected with raised-faced 150# ANSI flanges using a full-faced or ring gasket. Mating flanges should be flat within 0.020", clean, free of scratches, corrosion and tool marks
3. Each valve is leak tested at the factory as part of our standard inspection procedures.
4. Inspect the gasket; make sure that the material is suitable for the service. Gasket dimensions are listed in Table 1. Full gaskets must be used with flat face flanges. Either full or ring gaskets may be used with raised face flanges.

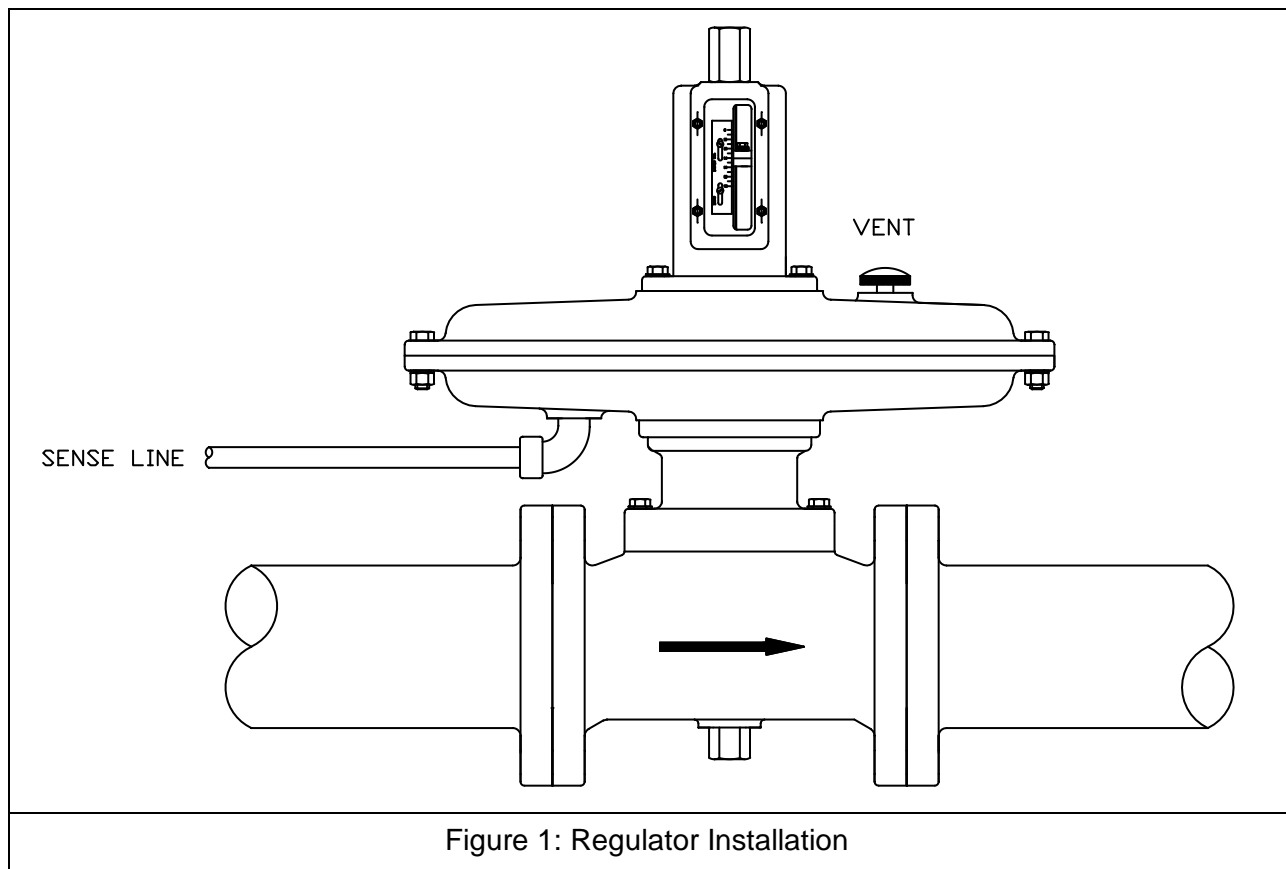

Table 1						
Inlet/Outlet Flange Gasket Dimensions						
ANSI 150#	I.D.	Ring O.D.	Full Face Gasket			
			Outer Diameter	Bolt Circle	Hole Size	Hole Qty
2"	2.38"	4.12"	6.0 "	4.75"	0.75"	4
3"	3.50"	5.38"	7.5"	6.00"	0.75"	4
4"	4.50"	6.88"	9.0"	7.50"	0.75"	8
6"	6.62"	8.75"	11.0"	9.50"	0.88"	8
8"	8.62"	11.00"	13.5"	11.75"	0.88"	8
10"	10.80"	13.40"	16.0"	14.25"	1.00"	12
12"	12.80"	16.10"	19.0"	17.00"	1.00"	12
16"	16.00"	20.30"	23.5"	21.25"	1.12"	16

Table 2: Bolt Torque				
Flat Face & Raised Face Flange				
			Flat Face	Raised Face
Flange Size (ANSI 150#)	Qty. of Bolts	Stud Size (UNC)	Torque: Foot-Pound (Kg*m)	Torque: Foot-Pound (Kg*m)
2"	4	5/8"-11	81 (11)	31 (4.3)
3"	4	5/8"-11	106 (15)	43 (6.0)
4"	8	5/8"-11	68 (9.4)	29 (4.0)
6"	8	3/4"-10	101 (14)	51 (7.1)
8"	8	3/4"-10	142 (20)	78 (11)
10"	12	7/8"-9	138 (19)	75 (10)
12"	12	7/8"-9	179 (25)	93 (13)

Torque values are based on 30 PSI pressure

5. Lubricate all studs and nuts with an appropriate thread lubricant. If stainless steel fasteners are used, use an anti-seize lubricant such as moly-disulfide.
6. Align flanges and gaskets. Make sure the flow path is not restricted by valve or gasket misalignment.
7. Install nuts and lock washers and torque all fasteners to half the value listed in Table 2 below in a staggered, alternating pattern.
8. Make sure that the flanges are not distorted and that the gasket is evenly compressed.
9. Make up the final torque and check that no further nut rotation occurs at the specified torque value.

Regulator flow capacity is based on a fully open regulator flowing air or a vapor with SG=0.7. Consult factory for capacity under other conditions

The regulator sense line is to be connected to the process line at a location at least ten feet upstream with a minimum of 0.31" ID tubing. The sense port on the regulator is on the lower surface of the actuator housing (see Figure 1). This line must be kept open and unobstructed to ensure that the regulator "senses" the actual line pressure. Long sense lines may require a larger diameter and care must be taken to assure that the line is self-draining. For some applications, a nitrogen purge may be required to ensure that this line remains open. Consult the factory for recommendations for remote installations or vapors that may cause line obstructions.

All system piping must be free of weld slag and other debris before installing the regulator.

OPERATION

The regulator is set at the factory. The pressure setting can be changed while installed in the process piping system. The purpose of the regulator is to maintain set pressure at some point upstream in the process, such as in the anaerobic digester tank. System pressure shall be monitored at this point.

Set pressure is set at the factory according to purchasing specifications. The range of set pressure for standard springs are shown in Table 3. Other ranges are available with special springs. The factory setting and spring range are shown on the nameplate. The regulator will not function properly if the setting is outside this range. If higher or lower settings are required, the necessary components can be obtained from Groth Corporation.

For in-line adjustment, a visible scale shows the approximate set pressure. From this setting, small adjustments can be made while observing upstream system pressure. Remove the cap [1] and turn the adjusting screw counter-clockwise to increase pressure or clockwise to decrease pressure. Replace the cap when adjustment is complete.

TABLE 3				
SPRING TABLE: MODEL 8860				
Flange Size	Min. Setting	Max. Setting	Spring P/N	Scale P/N
2"	2" WC	12" WC	SPR8860020120	313000101
2"	8" WC	24" WC	SPR8860020220	313000201
3" & 4"	2" WC	12" WC	SPR8860030120	313000101
3" & 4"	8" WC	24" WC	SPR8860030220	313000201
6" & 8"	2" WC	12" WC	SPR8860060120	313000101
6" & 8"	8" WC	24" WC	SPR8860060220	313000201
10" & 12"	2" WC	6" WC	SPR8860100320	313000301
10"	5" WC	12" WC	SPR8860100520	313000401
10" & 12"	10" WC	22" WC	SPR8860100420	313000501
10" & 12"	20" WC	44" WC	SPR8860100620	313000601
12"	3" WC	8" WC	SPR8860100520	313000701
12"	5" WC	12" WC	SPR8860120520	313000401

PROBLEM	INSPECTION	SUGGESTED CORRECTIVE ACTION
Vapor flowing at line pressure below specified set point.	Flow indicator or vapor discharge.	Damaged seat/disc or setting too low. If original pressure setting has not been disturbed, remove regulator and repair.
Vapor not flowing at line pressure above specified set point.	Flow indicator or vapor discharge.	Damaged diaphragm or pressure setting too high. If original pressure setting has not been disturbed, remove regulator and repair. Inspect the bushings for debris or damage.
Gas leaking from upper vent.	Emission indication near the regulator.	Damaged diaphragm. Remove regulator and replace diaphragm.
System pressure above specified operating range.	Observe pressure indicator during operation.	Damaged diaphragm or pressure setting too high. Vapor flow exceeds capacity of regulator.
System pressure below specified operating range.	Observe pressure indicator during operation.	Damaged seat/disc or setting too low. Insufficient vapor production.

TROUBLESHOOTING GUIDE

PREVENTIVE MAINTENANCE

Periodically, while in service, examine the regulator for leakage at bolted connections, adjusting screws, and vent. Test for process vapor emissions from vent caps.

Periodically, out of service, examine seat and pallet for a smooth surface to ensure proper seating and sealing. Examine actuator diaphragm for cuts, or unusual wear.

RECOMMENDED SPARE PARTS

The following spare parts should be stocked for maintenance purposes:

- Spring; See Table 3 for the correct part number.
- Vent part number 285320147 (1/4" NPT).
- Soft Goods Kit; See Table 4 for the correct part number.
- Note: The soft goods kits include all items marked with an (*) in Table 5 or Table 6.

Size	Buna-N	EPDM	Viton
2"-4"	KS88602B	KS88602E	KS88602V
6"-8"	KS88606B	KS88606E	KS88606V
10"-12"	KS886010B	KS886010E	KS886010V

When ordering spare parts, include model and serial number of regulator, pressure setting, and required material for soft goods.

Groth Model 8860 Back Pressure Regulator (2"-8")

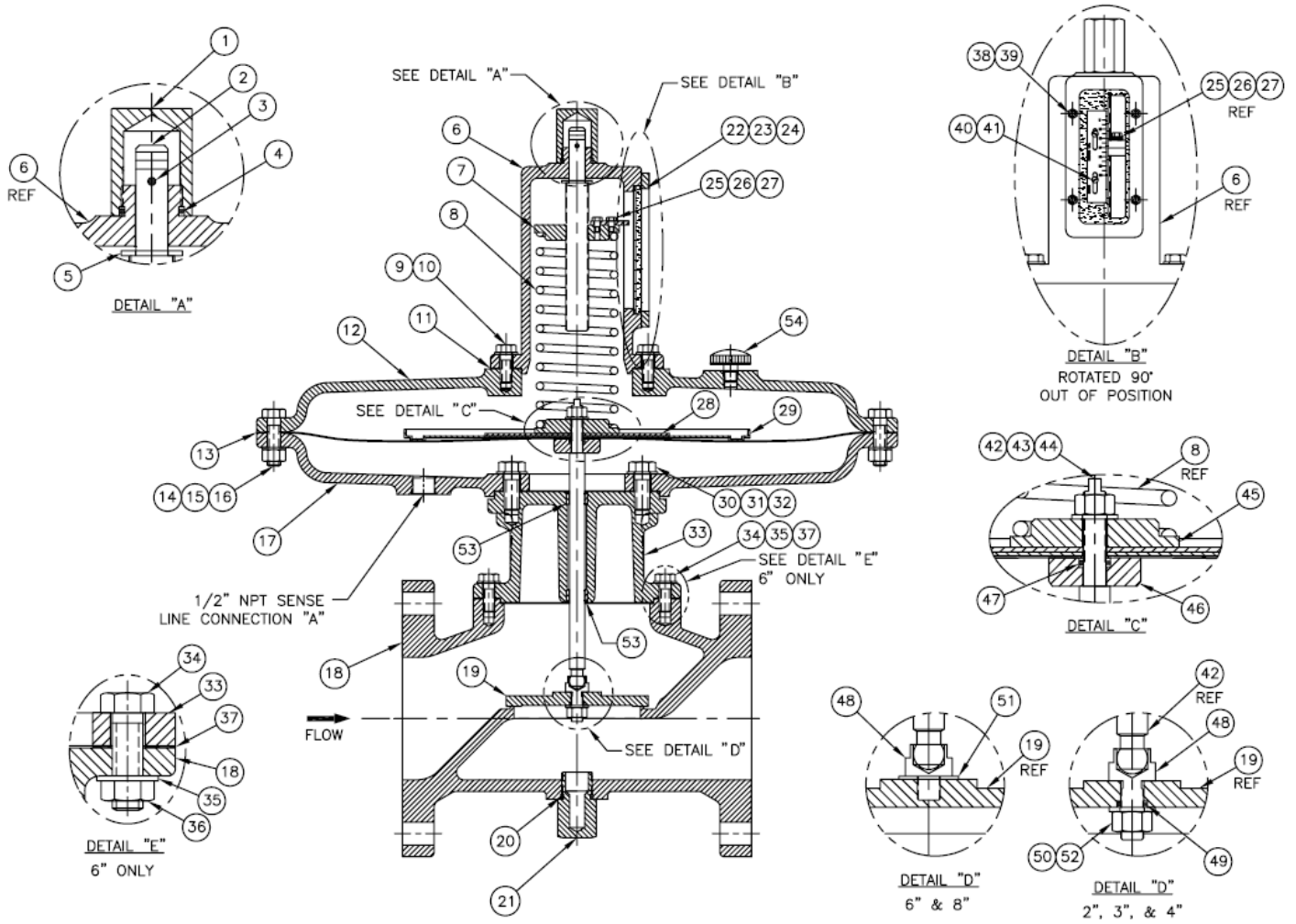

Figure 1: Cross-Sectional Assembly (2"-8")

Table 5: Bill of Materials (2"-8")

ITEM	DESCRIPTION	ITEM	DESCRIPTION
1	CAP-HOUSING	28	SUPPORT PLATE
2	ADJUSTMENT SCREW	29	RETAINER PLATE
3	ROLL PIN	30	HEX BOLT
4	* O-RING-UPPER HOUSING CAP	31	LOCK WASHER
5	WASHER	32	* GASKET-SPOOL LOWER CASE
6	SPRING HOUSING	33	SPOOL
7	SPRING BUTTON-UPPER	34	HEX BOLT
8	SPRING	35	LOCK WASHER
9	HEX BOLT	36	HEX NUT (6" ONLY)
10	LOCK WASHER	37	* GASKET-BODY
11	* GASKET-SPRING HOUSING	38	HEX BOLT
12	UPPER-DIAPHRAGM CASE	39	LOCK WASHER
13	* DIAPHRAGM	40	MACHINE SCREW
14	HEX BOLT	41	SCALE
15	LOCK WASHER	42	STEM
16	HEX NUT	43	HEX JAM NUT
17	LOWER-DIAPHRAGM CASE	44	BELLEVILLE WASHER
18	BODY	45	SPRING BUTTON-LOWER
19	PALLET	46	SPACER
20	* O-RING-LOWER CAP	47	* O-RING-SPACER
21	PLUG	48	SWIVEL FITTING
22	* GASKET-SIGHT GLASS	49	* O-RING-SWIVEL FITTING (2"-4" ONLY)
23	SIGHT GLASS	50	FLAT WASHER (2"-4" ONLY)
24	COVER-SIGHT GLASS	51	BELLEVILLE WASHER (6"-8" ONLY)
25	HEX BOLT	52	LOCK NUT (2"-4" ONLY)
26	LOCK WASHER	53	BUSHING
27	INDICATOR-PRESSURE	54	VENT

* Spare Parts

Groth Model 8860 Back Pressure Regulator (10"-12")

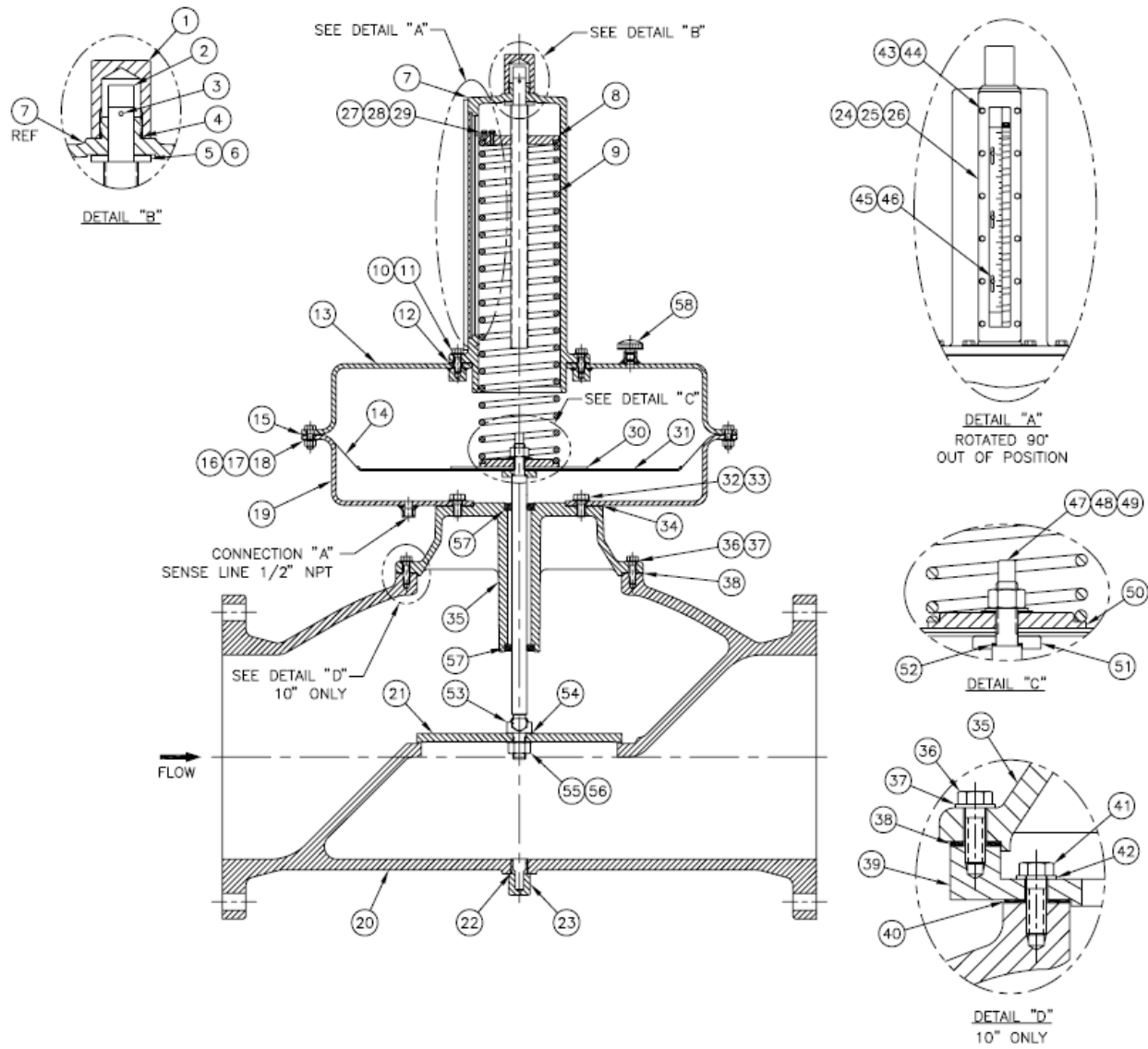

Figure 2: Cross-Sectional Assembly (10"-12")

Table 6: Bill of Materials (10"-12")

ITEM	DESCRIPTION	ITEM	DESCRIPTION
1	CAP-HOUSING	30	SUPPORT PLATE
2	ADJUSTMENT SCREW	31	RETAINER PLATE
3	ROLL PIN	32	HEX BOLT
4	* O-RING-UPPER HOUSING CAP	33	LOCK WASHER
5	WASHER	34	* GASKET-SPOOL LOWER CASE
6	WASHER	35	SPOOL
7	SPRING HOUSING	36	HEX BOLT
8	SPRING BUTTON-UPPER	37	LOCK WASHER
9	SPRING	38	* GASKET-BODY
10	HEX BOLT	39	ADAPTER PLATE (10" ONLY)
11	LOCK WASHER	40	* GASKET (10" ONLY)
12	* GASKET-SPRING HOUSING	41	HEX BOLT (10" ONLY)
13	UPPER-DIAPHRAGM CASE	42	LOCK WASHER (10" ONLY)
14	* DIAPHRAGM	43	HEX BOLT
15	* GASKET-DIAPHRAGM CASE	44	LOCK WASHER
16	HEX BOLT	45	MACHINE SCREW
17	LOCK WASHER	46	SCALE
18	HEX NUT	47	STEM
19	LOWER-DIAPHRAGM CASE	48	HEX JAM NUT
20	BODY	49	BELLEVILLE WASHER
21	PALLET	50	SPRING BUTTON-LOWER
22	* O-RING-LOWER CAP	51	SPACER
23	PLUG	52	* O-RING-SPACER
24	* GASKET-SIGHT GLASS	53	SWIVEL FITTING
25	SIGHT GLASS	54	* GASKET-SWIVEL FITTING
26	COVER-SIGHT GLASS	55	BELLEVILLE WASHER
27	HEX BOLT	56	HEX JAM NUT
28	LOCK WASHER	57	BUSHING
29	INDICATOR-PRESSURE	58	VENT

* Spare Parts

MODEL INFORMATION

The nameplate on the Groth Model 8860 Back Pressure Regulator contains the model number, serial number, set pressure & set pressure range. The model number contains additional information about material of construction, capacity and options. The following chart will assist in relating the model number to the specifications of your regulator:

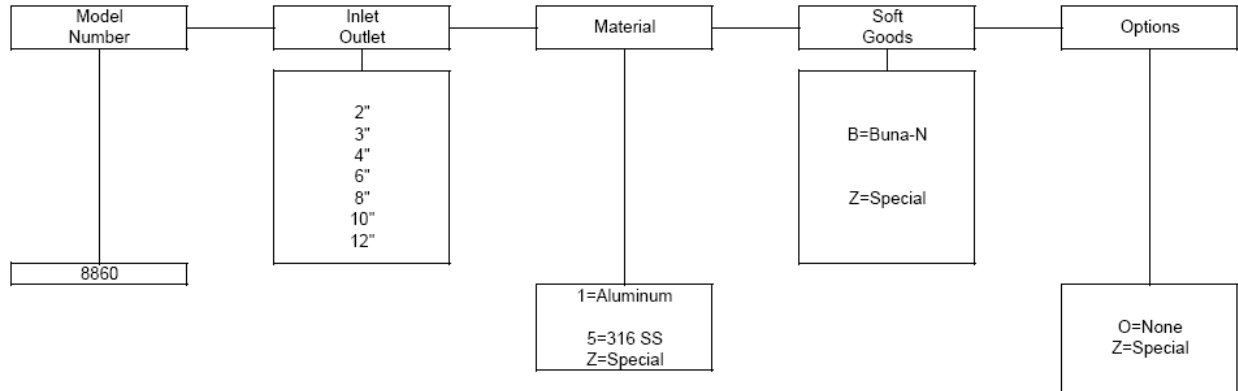

A "Z" in the model number indicates a non-standard material or feature. Review your purchase specifications or consult Groth Corporation for more details.

EXAMPLE: 8860-4-5-B-O Indicates a Model 8860 Back Pressure Regulator with 4" 150# ANSI flanges, 316 SS construction, Buna-N soft goods and no special options.

PRODUCT LIMITED WARRANTY

- A. Seller warrants that products which are manufactured by Seller, are manufactured in accordance with published specifications and free from defects in materials and/or workmanship for a period of (12) twelve months. Seller, at its option, will repair or replace any products returned intact to the factory, transportation charges prepaid, which Seller, upon inspection, shall determine to be defective in material and/or workmanship. The foregoing shall constitute the sole remedy for any breach of Seller's warranty.
- B. THERE ARE NO UNDERSTANDINGS, AGREEMENTS, REPRESENTATIONS, OR WARRANTIES, EXPRESS OR IMPLIED, (INCLUDING MERCHANTABILITY OR FITNESS FOR A PARTICULAR PURPOSE REGARDING PRODUCTS) UNLESS SPECIFIED IN THE SALES CONTRACT. THIS CONTRACT STATES THE ENTIRE OBLIGATION OF SELLER.

Seller makes no warranties, either express or implied, except as provided herein, including without limitation thereof,
- C. The original Manufacturer shall be solely responsible for the design, development, supply, production, and performance of its products hereunder, and the protection of its trade name or names, if any. It assumes no responsibility, for products modified or changed in any way by its agent or customer. Any such modifications or changes to products sold by Seller hereunder shall make the product limited warranty null and void.
- D. The Manufacturer shall be under no obligation to manufacture, sell, or supply, or to continue to manufacture, sell or supply any of the Products.